

### Assemble the right armrest

- 1. 15 mm plywood (Template №1) - 1
- 2. 15 mm plywood (Template №2) - 1

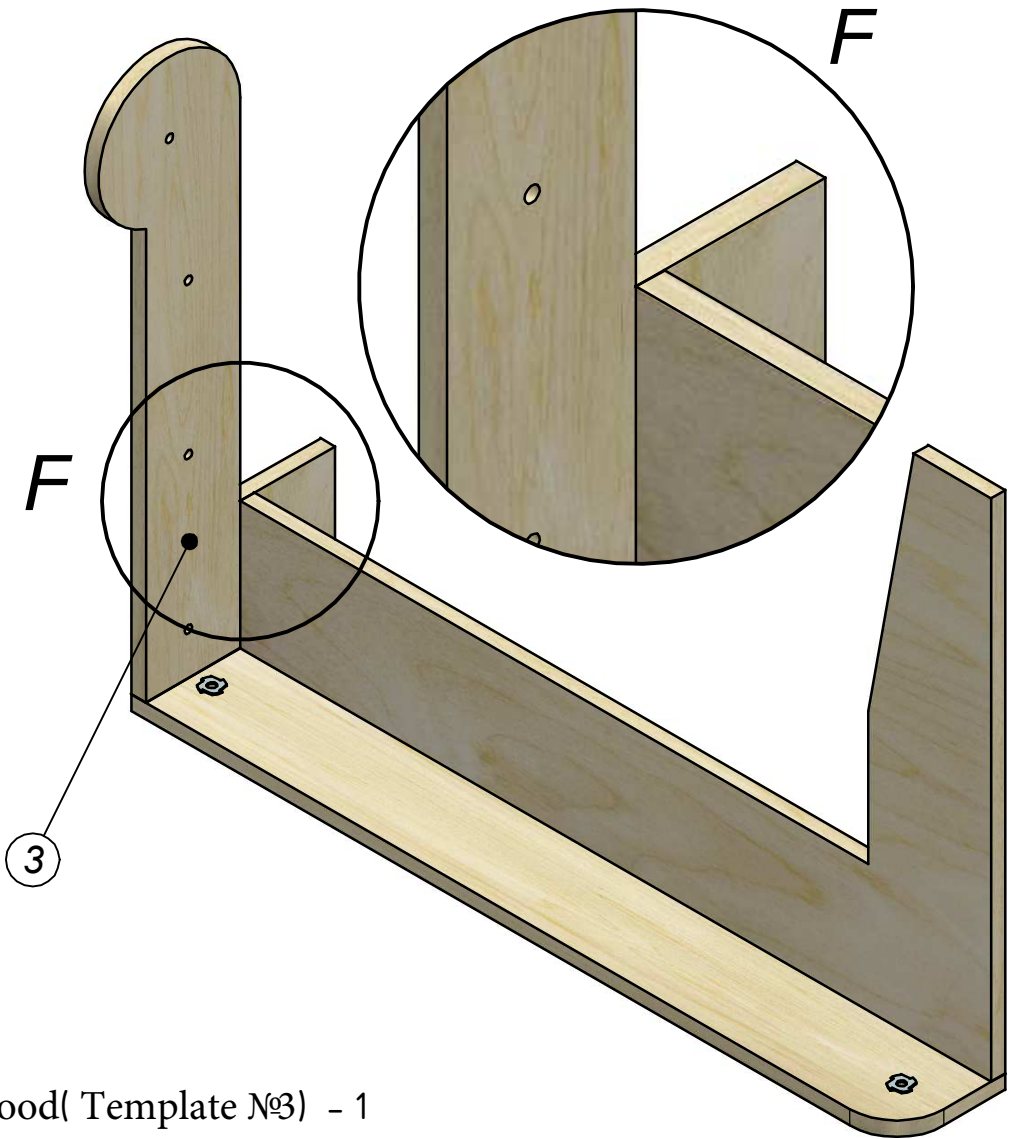

3. 15 mm plywood( Template №3) - 1

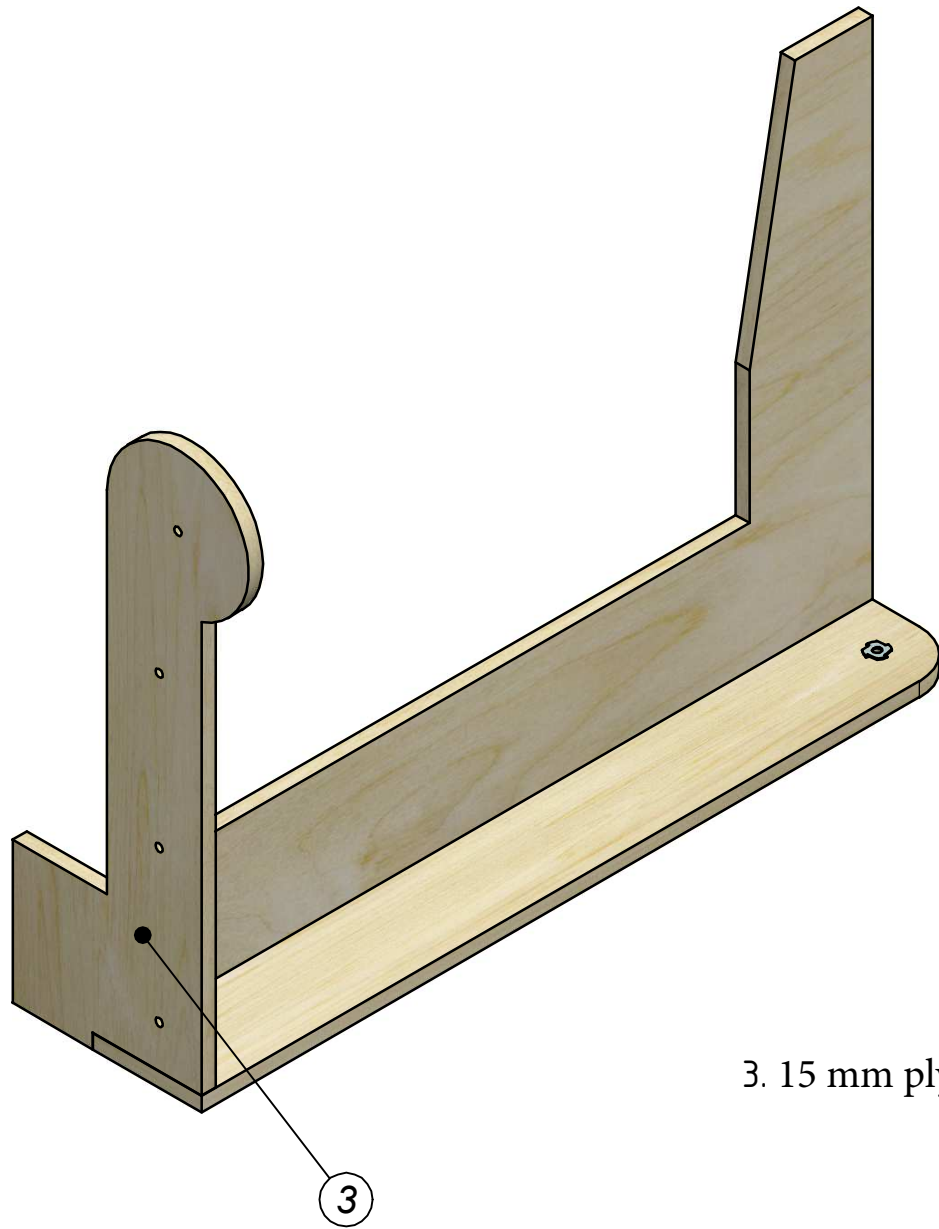
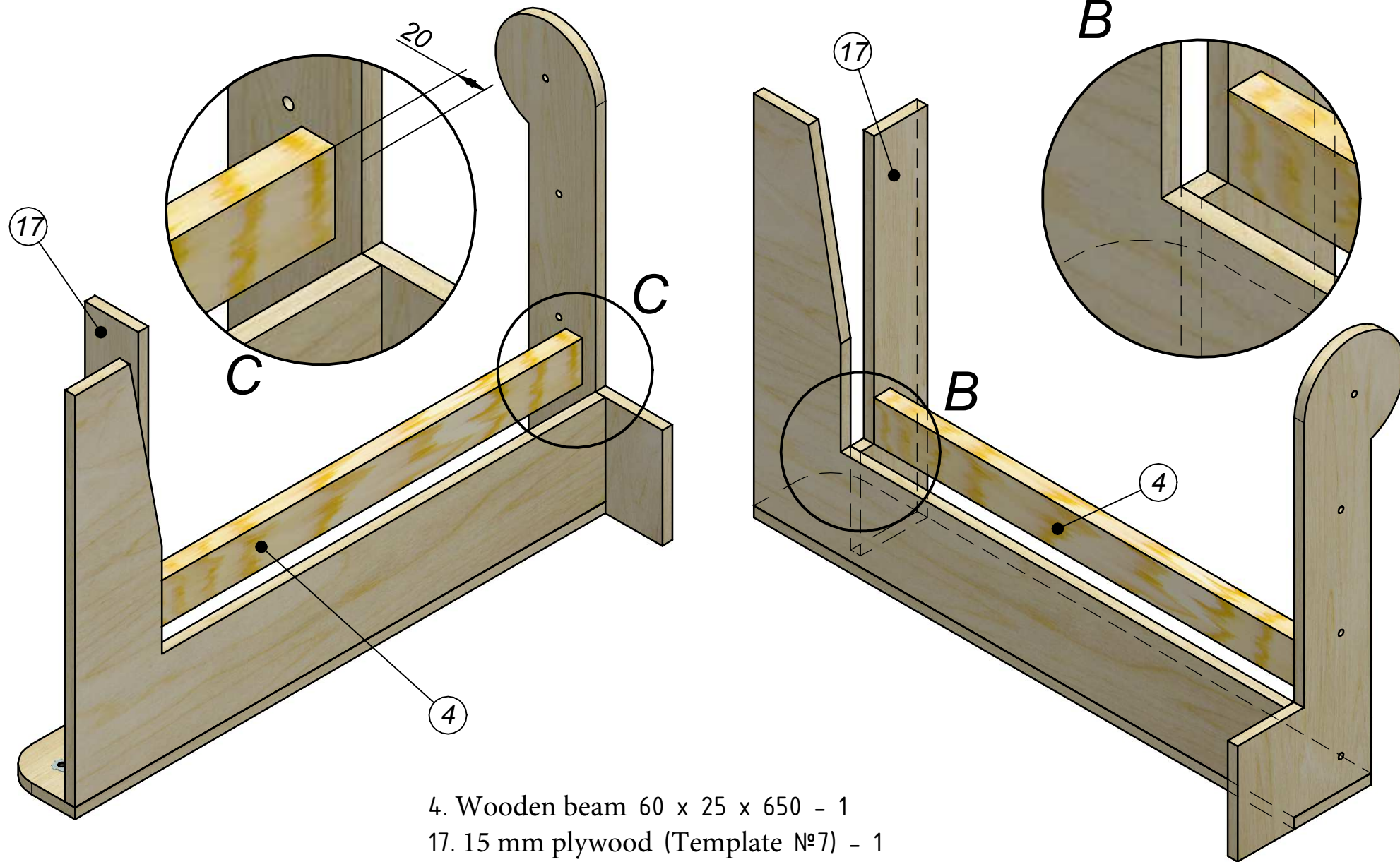

- 4. Wooden beam 60 x 25 x 650 - 1
- 17. 15 mm plywood (Template №7) - 1

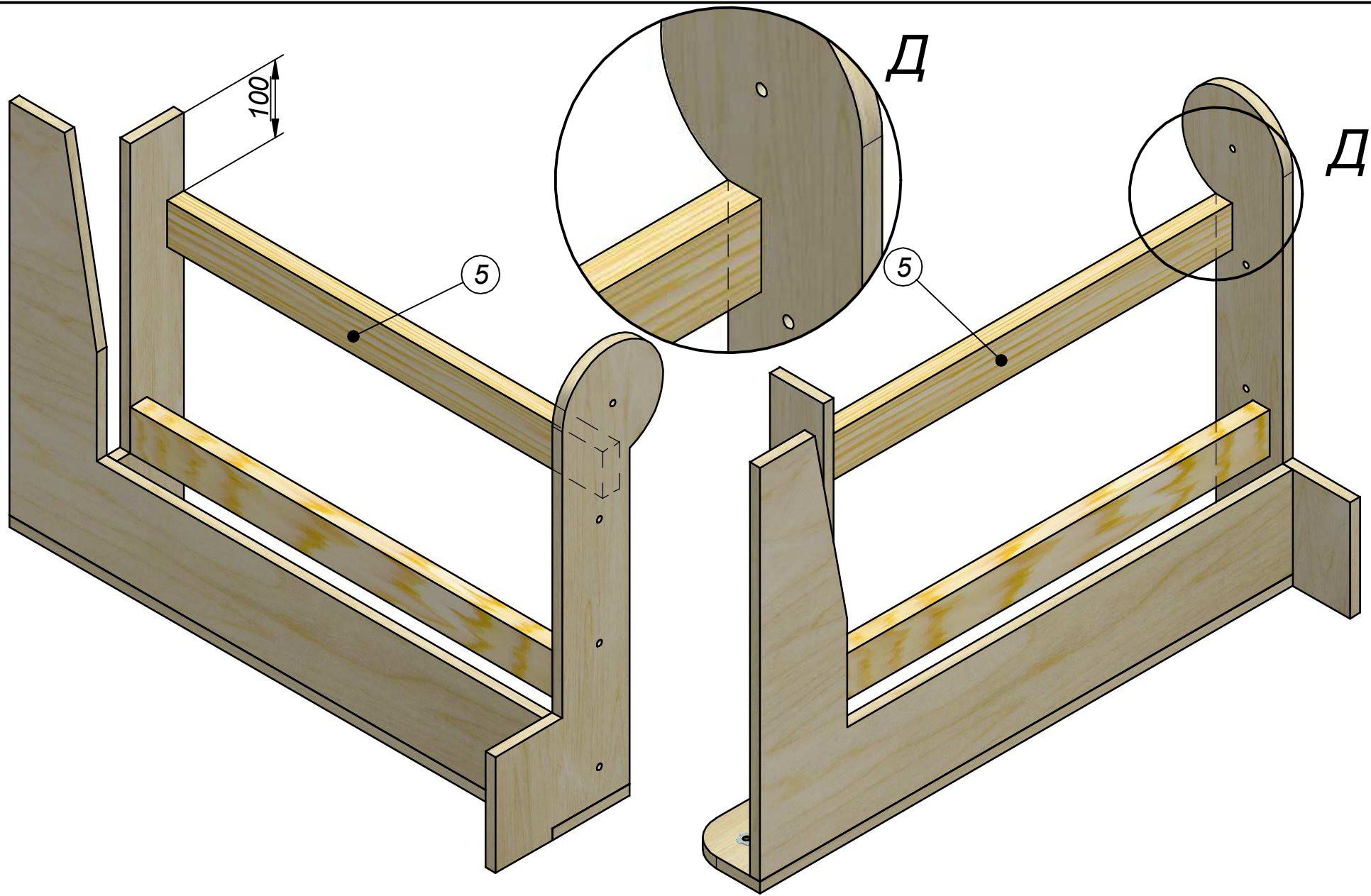

5. Wooden beam 60 x 25 x 650 - 1

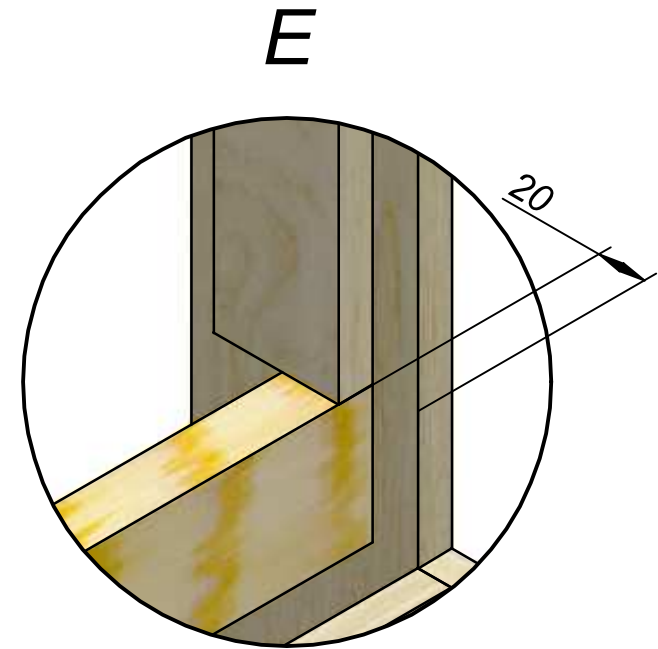
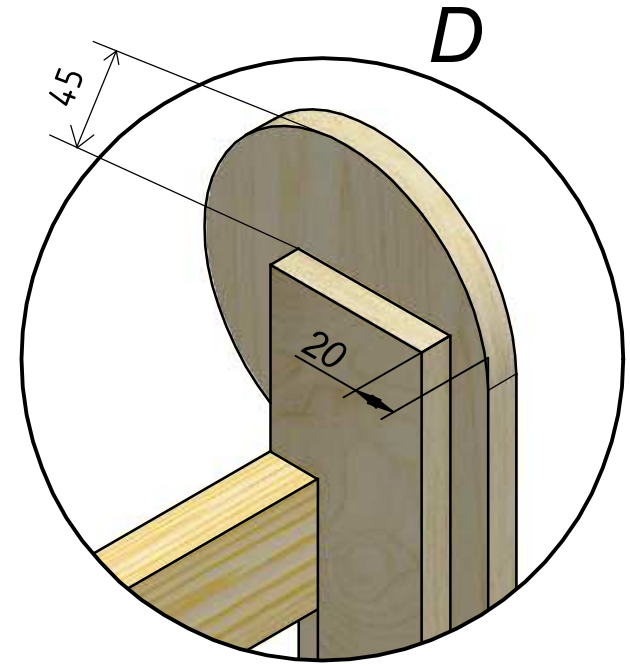
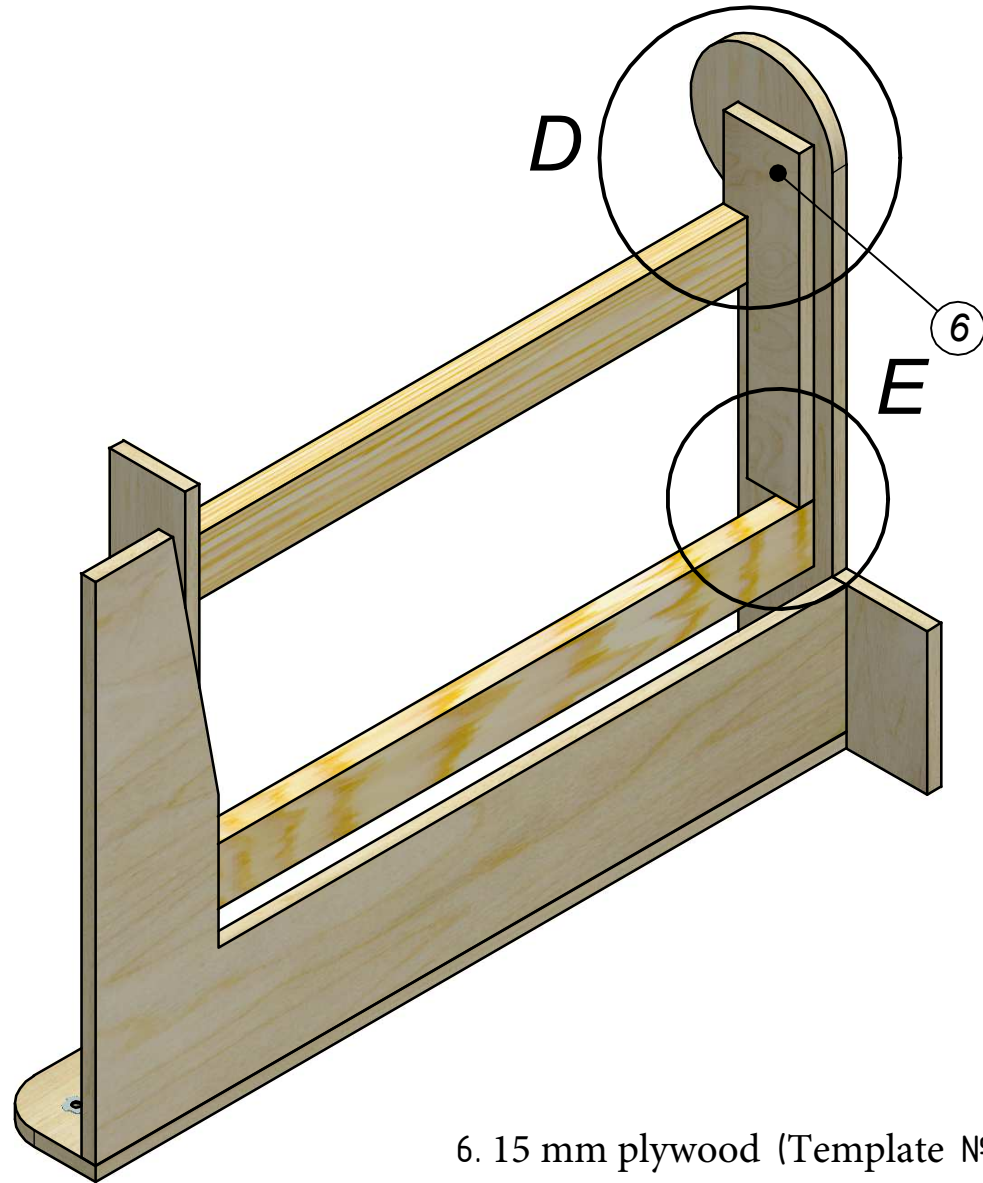

6. 15 mm plywood (Template №4) - 1

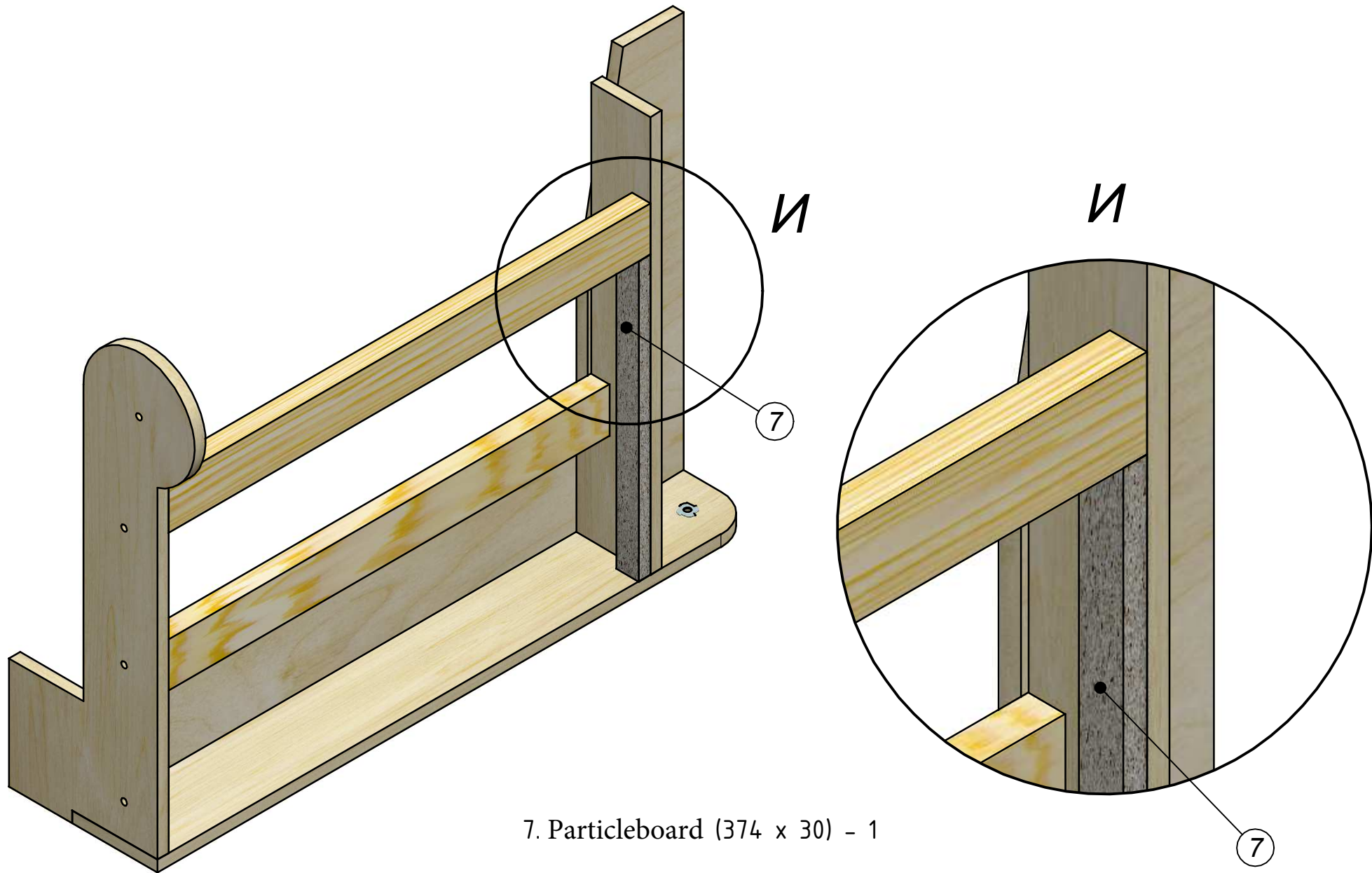

7. Particleboard (374 x 30) - 1

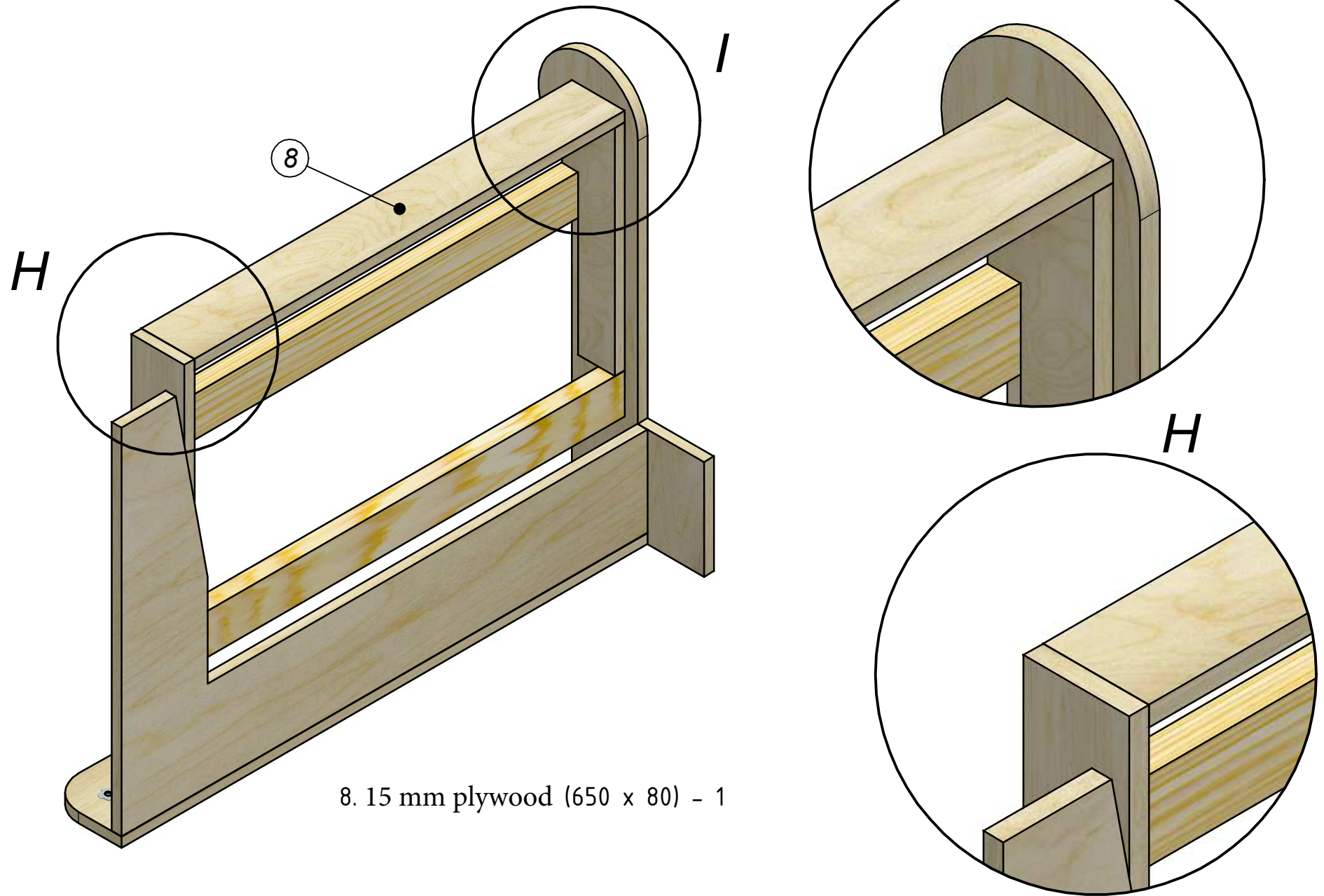

8. 15 mm plywood (650 x 80) - 1

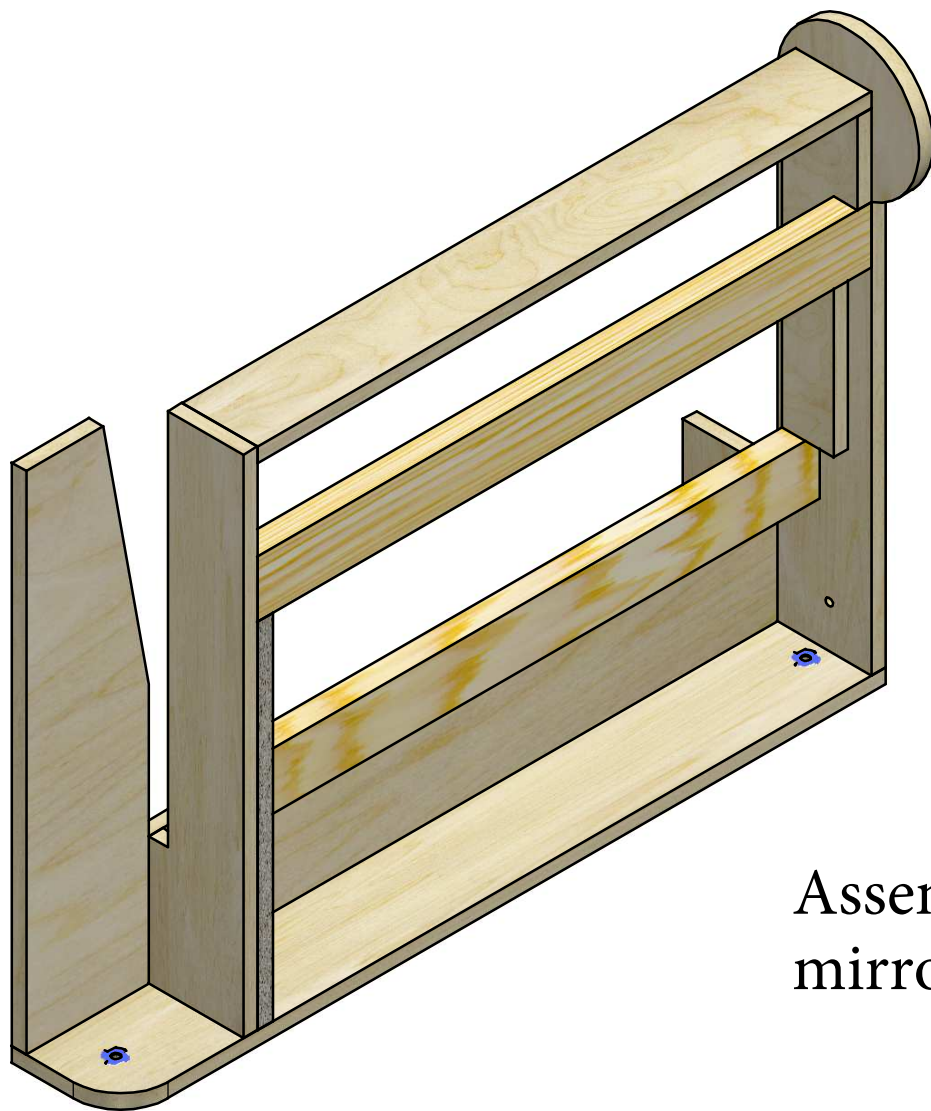

Assemble the left armrest as a mirror of the right armrest

Chesterfield chair

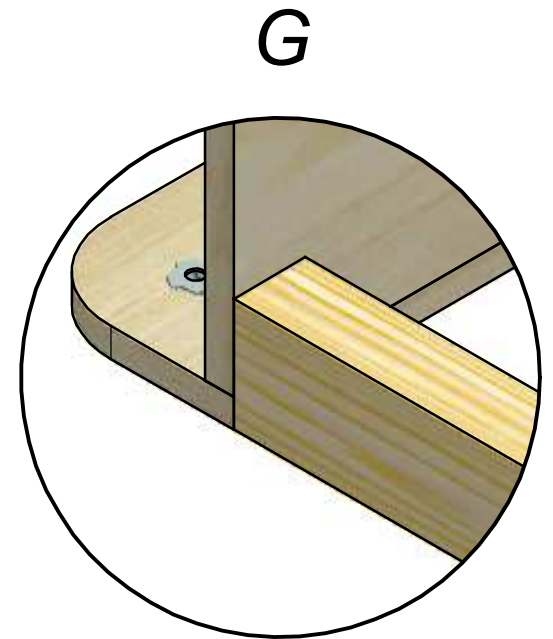
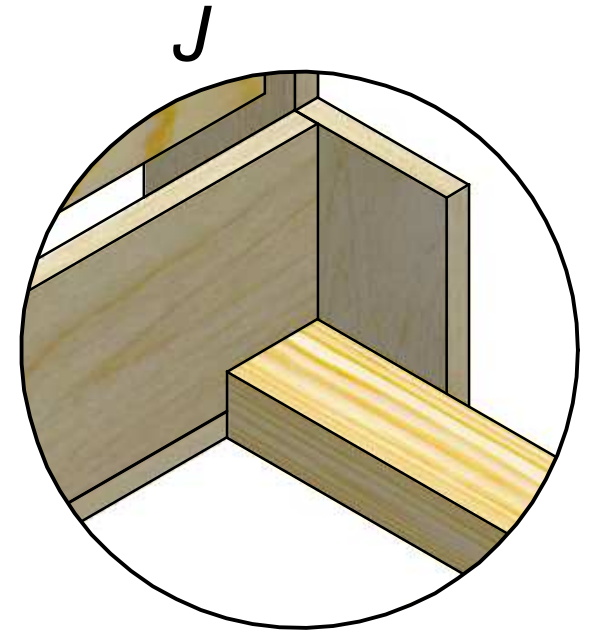
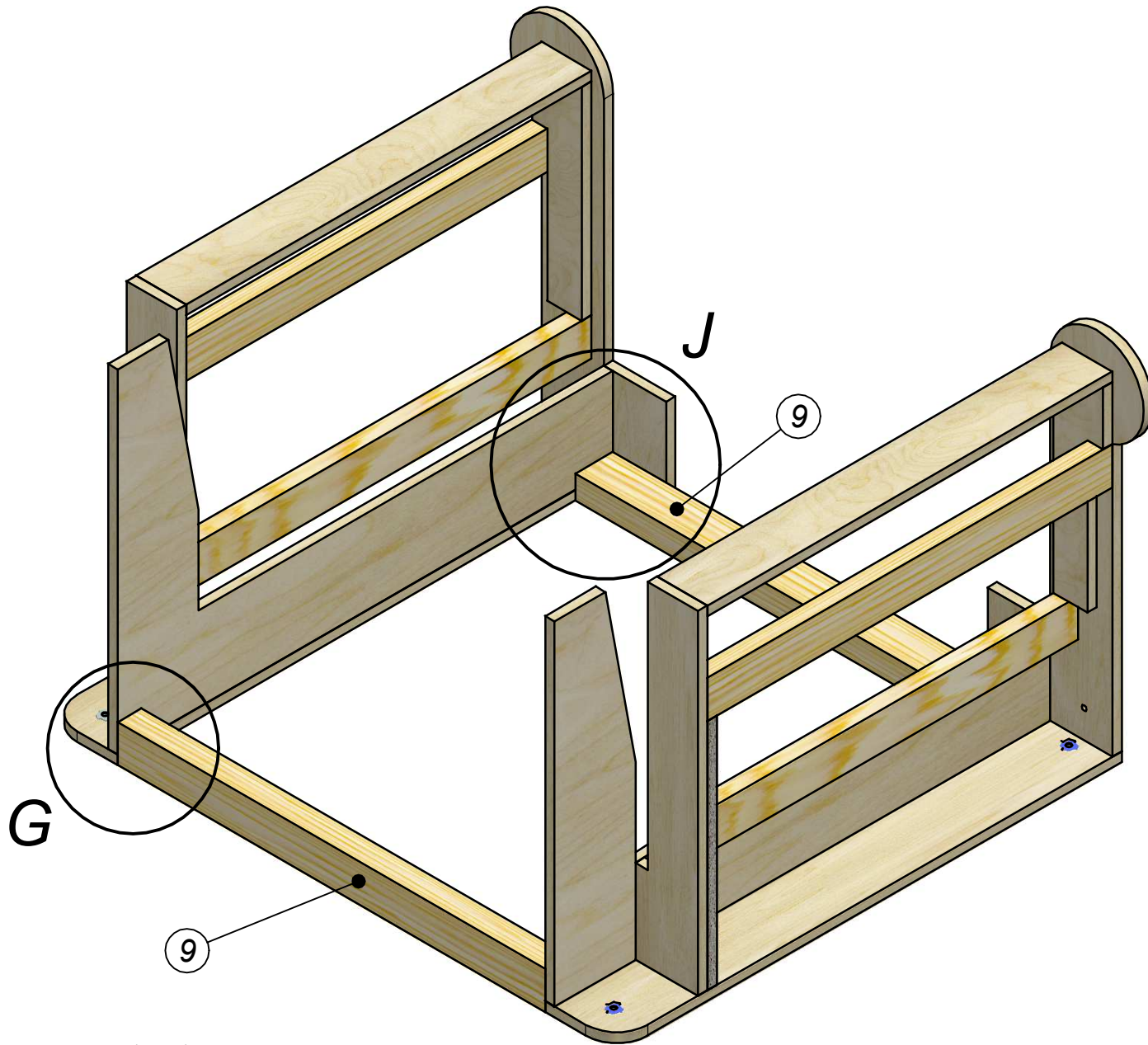

9. Wooden beam 60 x 38 x 686 - 2

Chesterfield chair

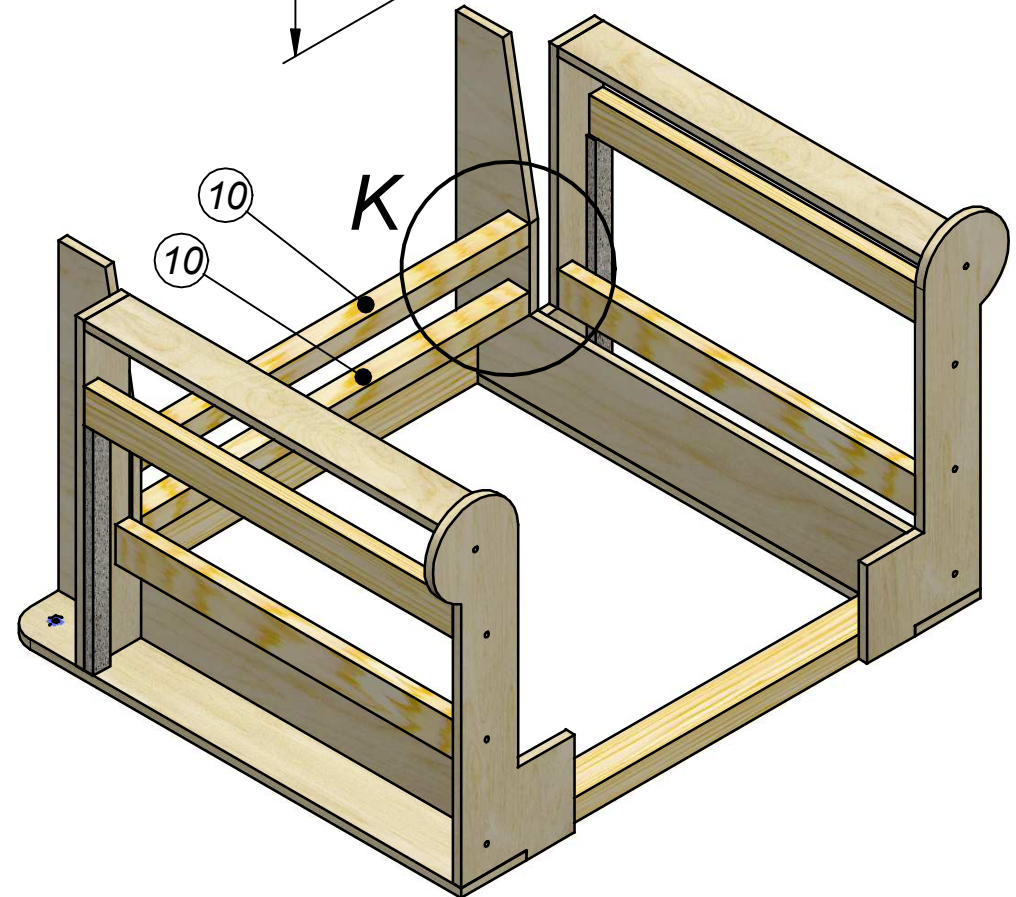
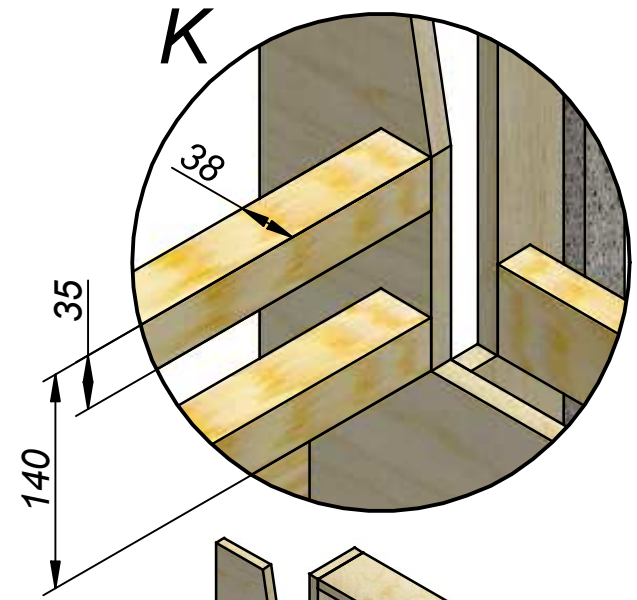
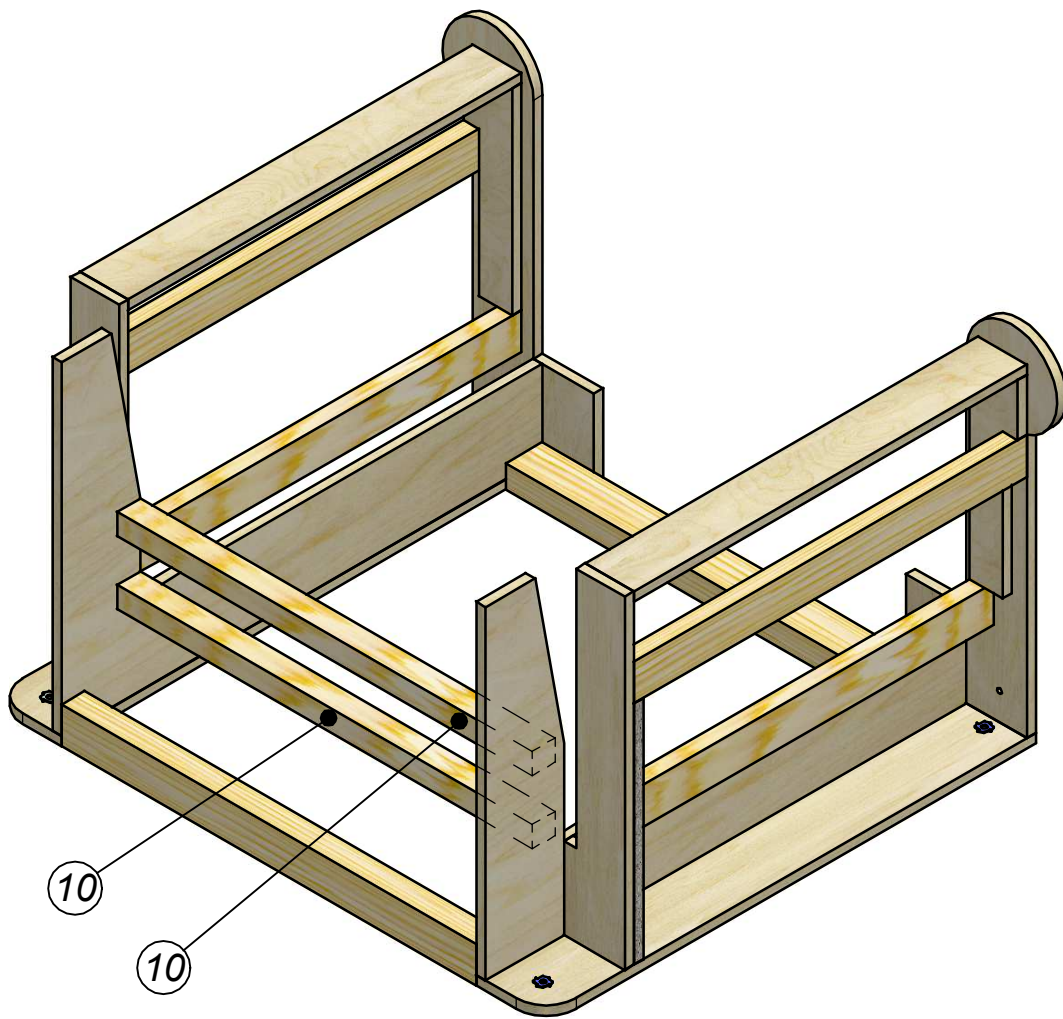

10. Wooden beam 35 x 38 x 686 - 2

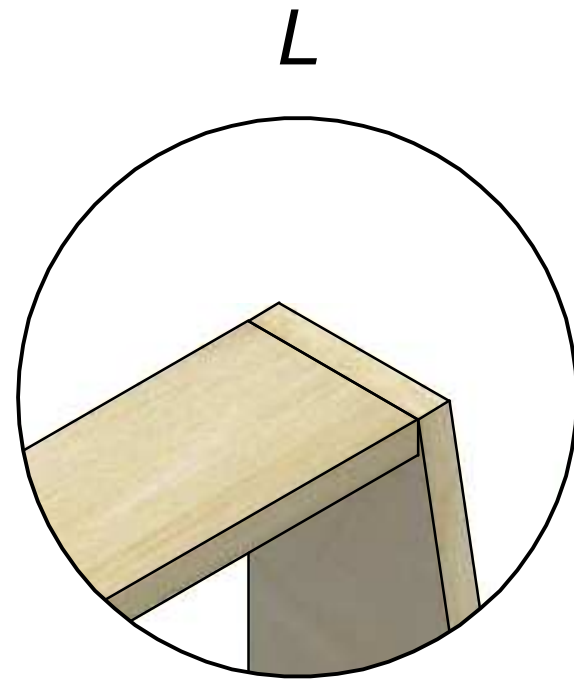
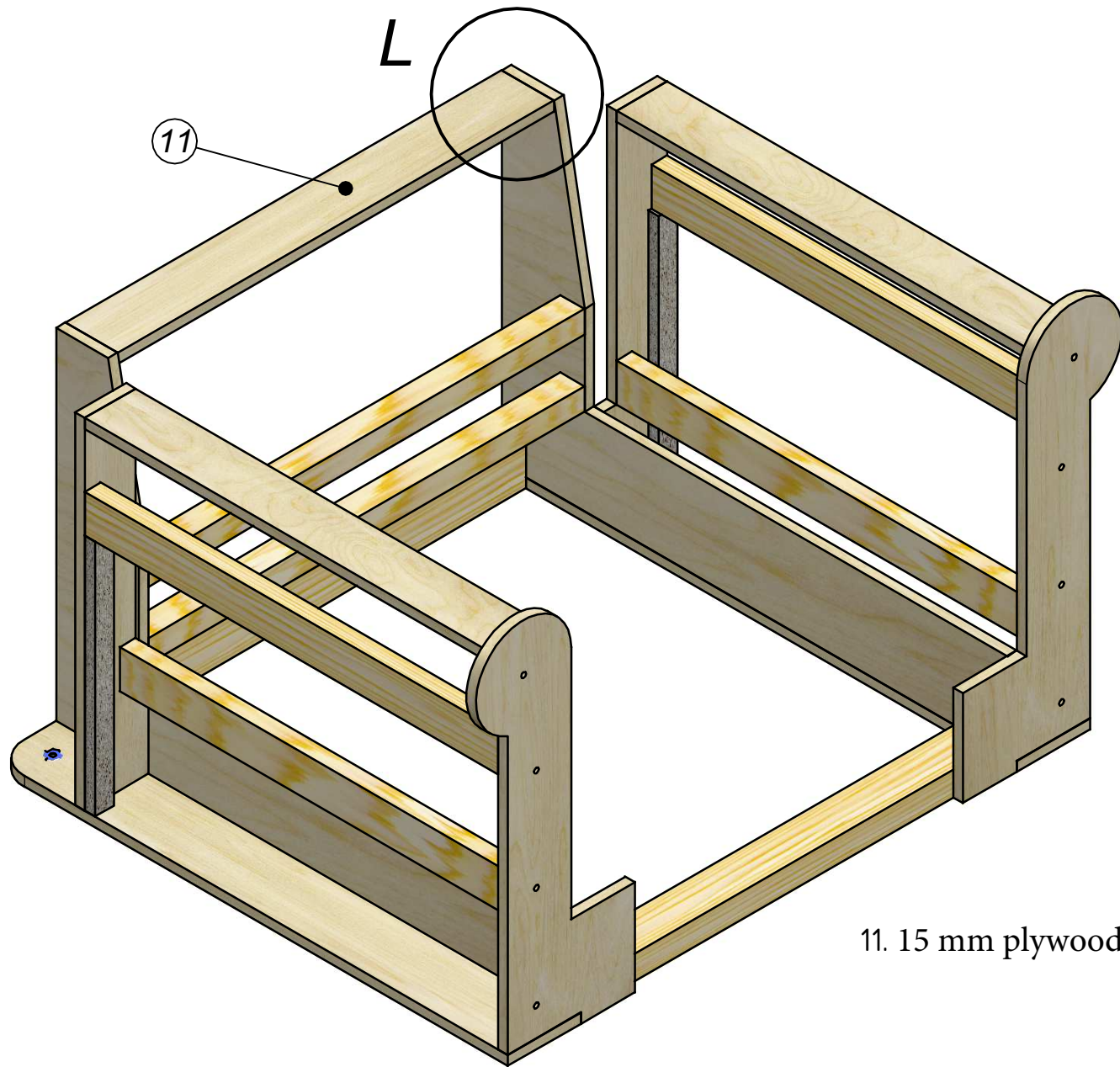

11. 15 mm plywood (686 x 82) - 1

Chesterfield chair

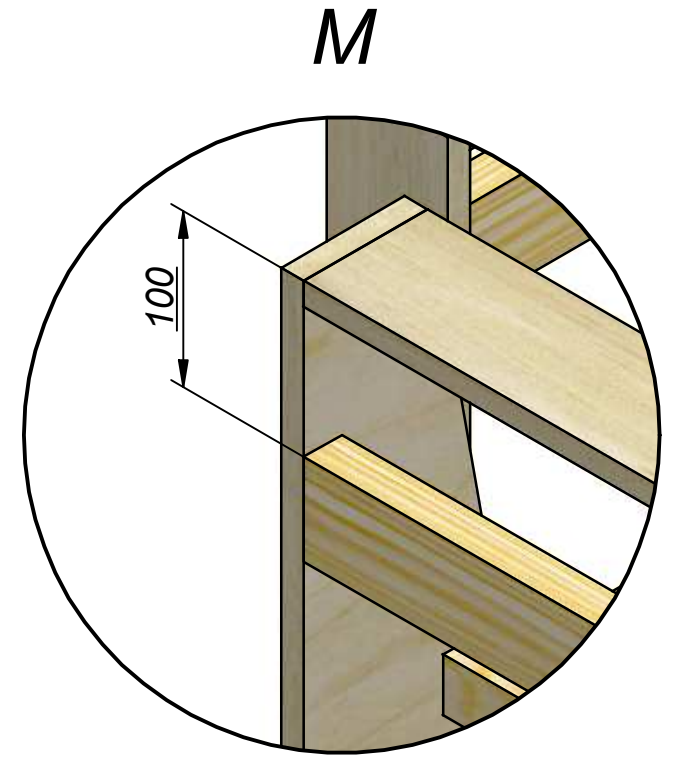
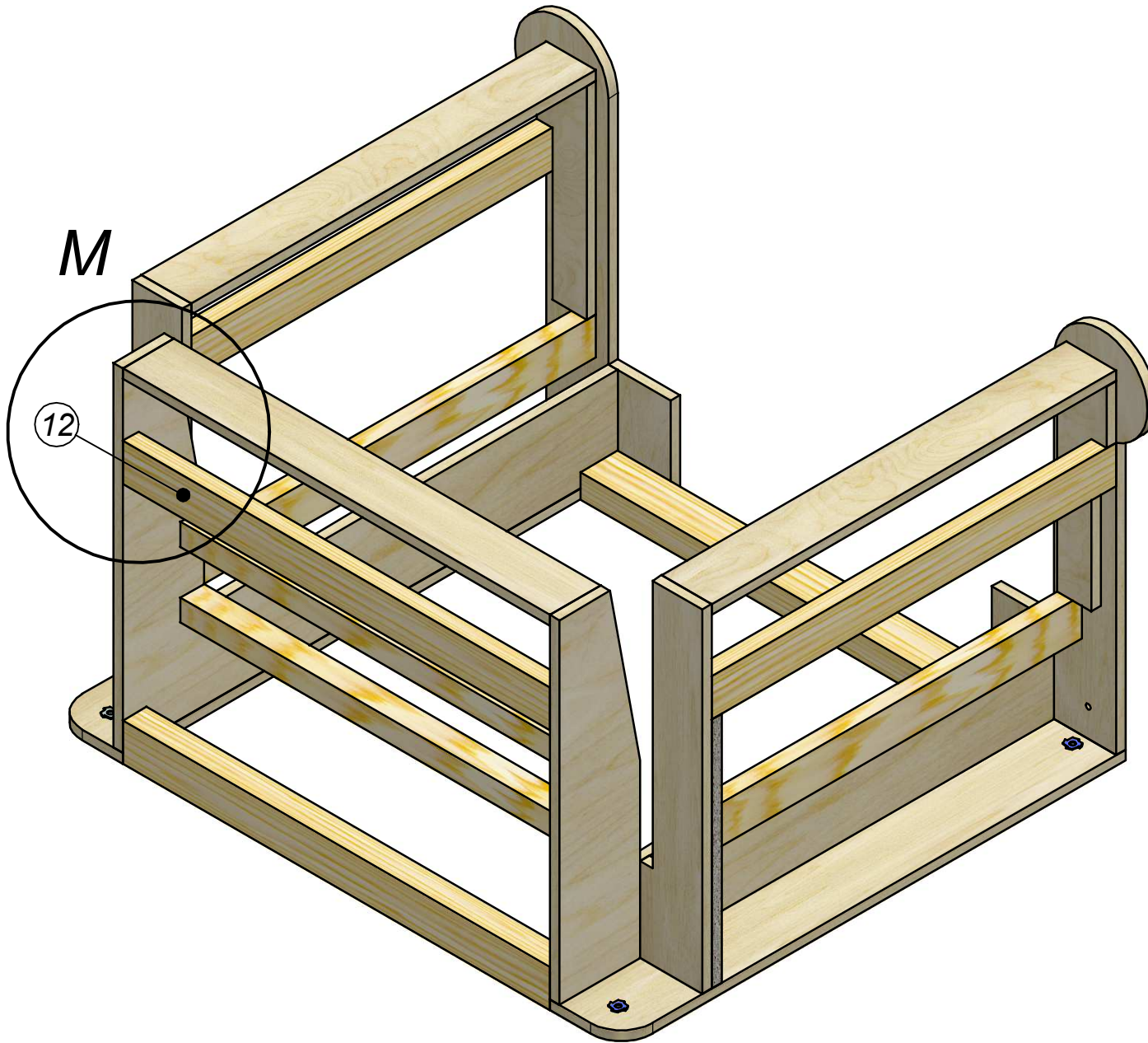

12. Wooden beam (60 x 25 x 686) - 1

Chesterfield chair

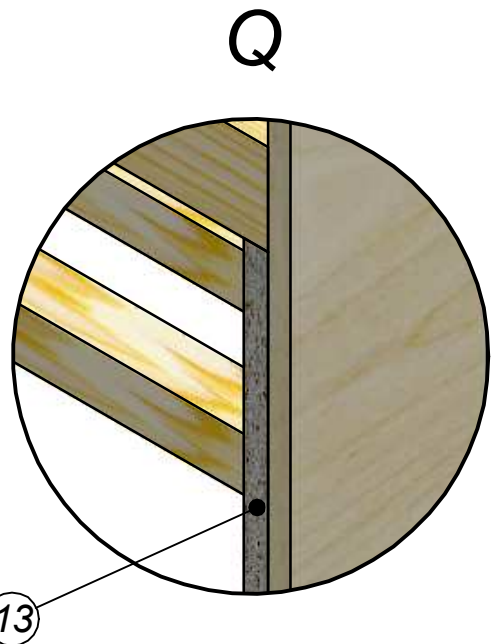
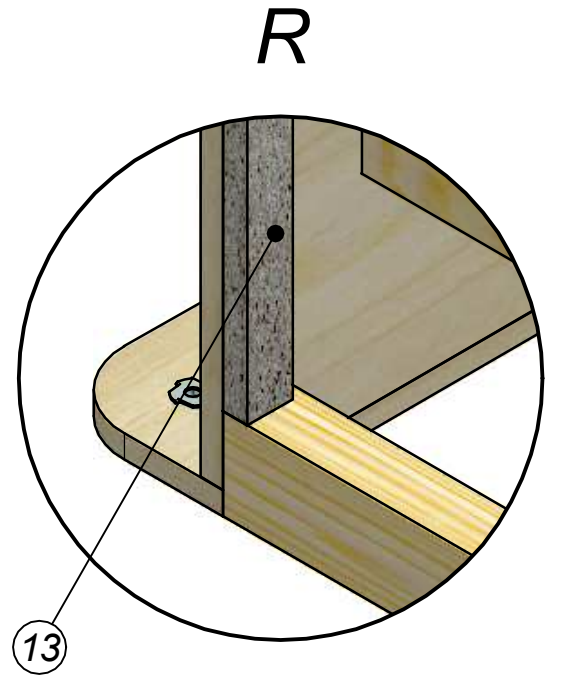
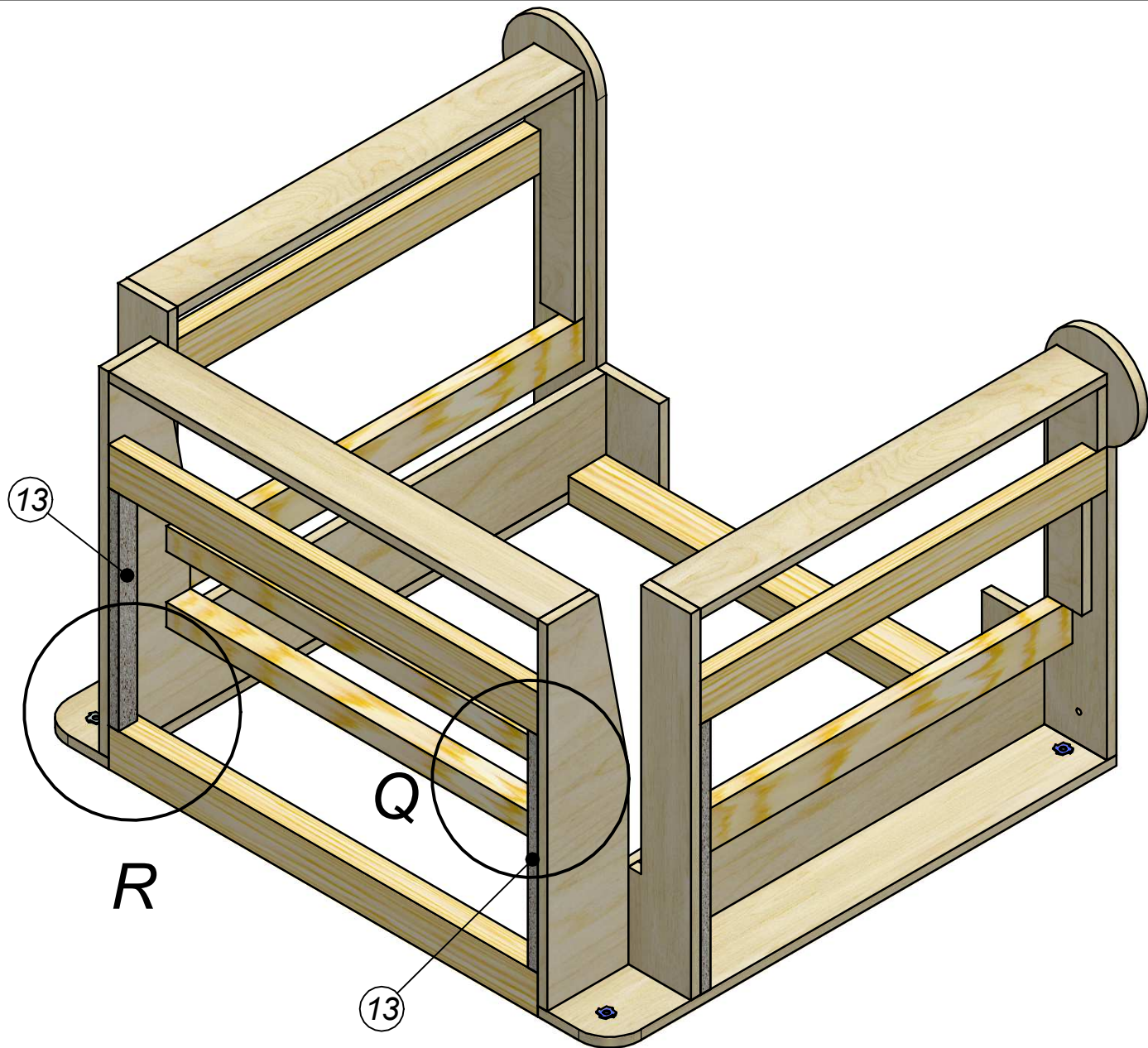

13. Particleboard ( 328x30)-2

Chesterfield chair

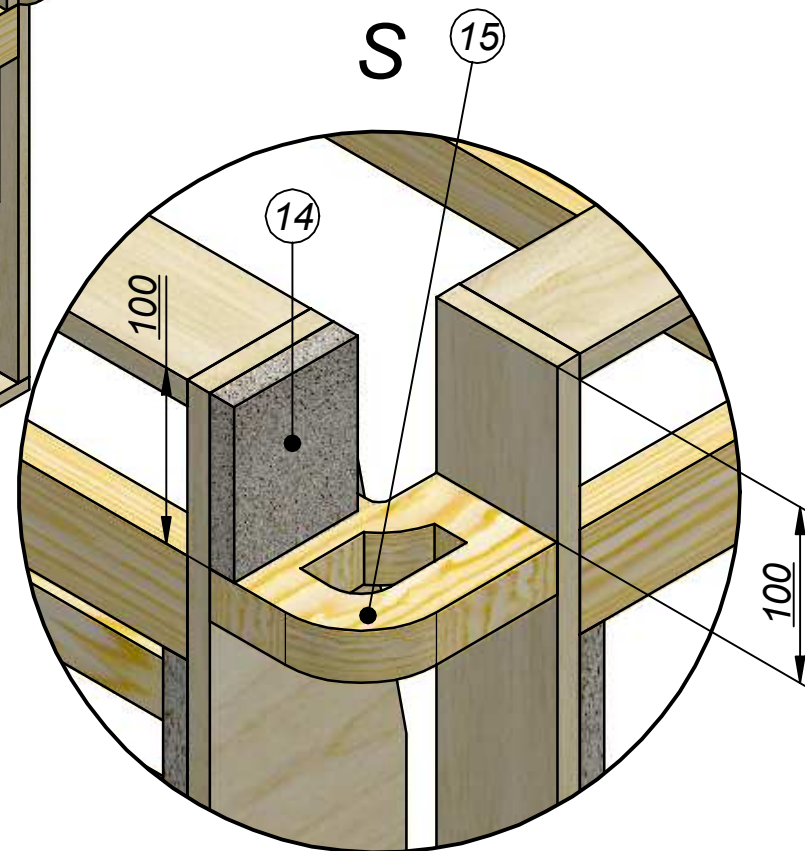
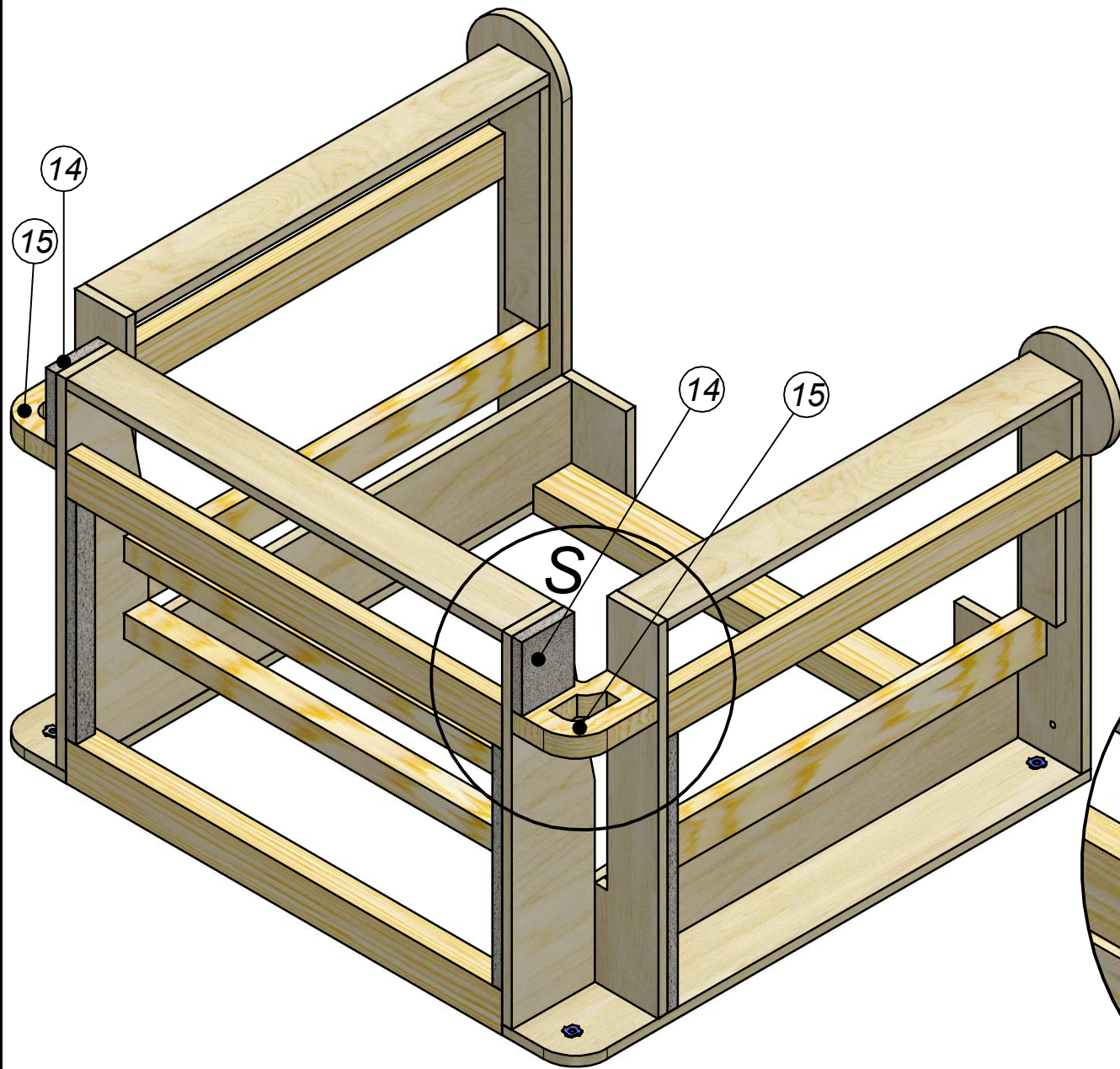

- 14. Particleboard ( 100x82)-2
- 15. Wooden beam36MM(Template №5)-2

Chesterfield chair

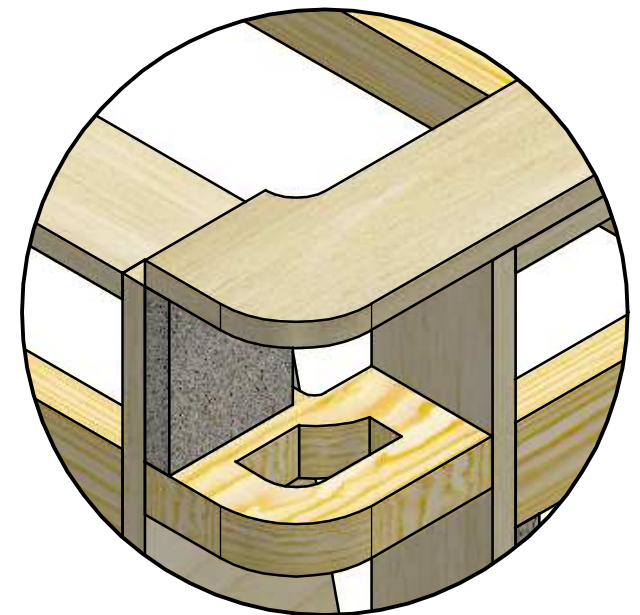
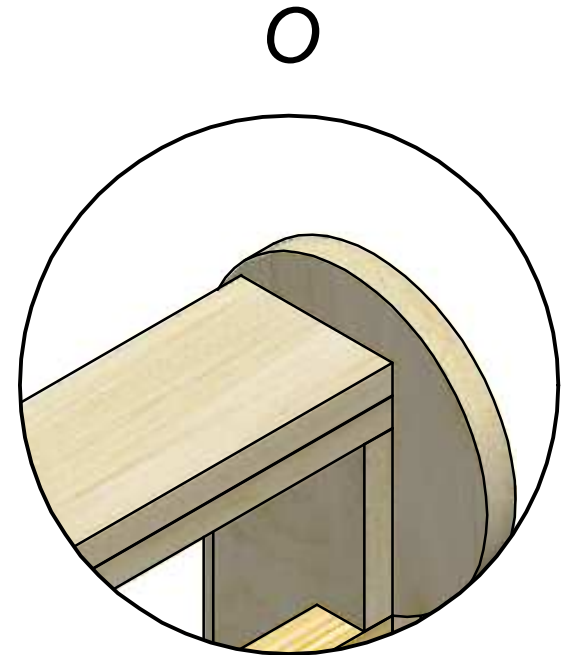
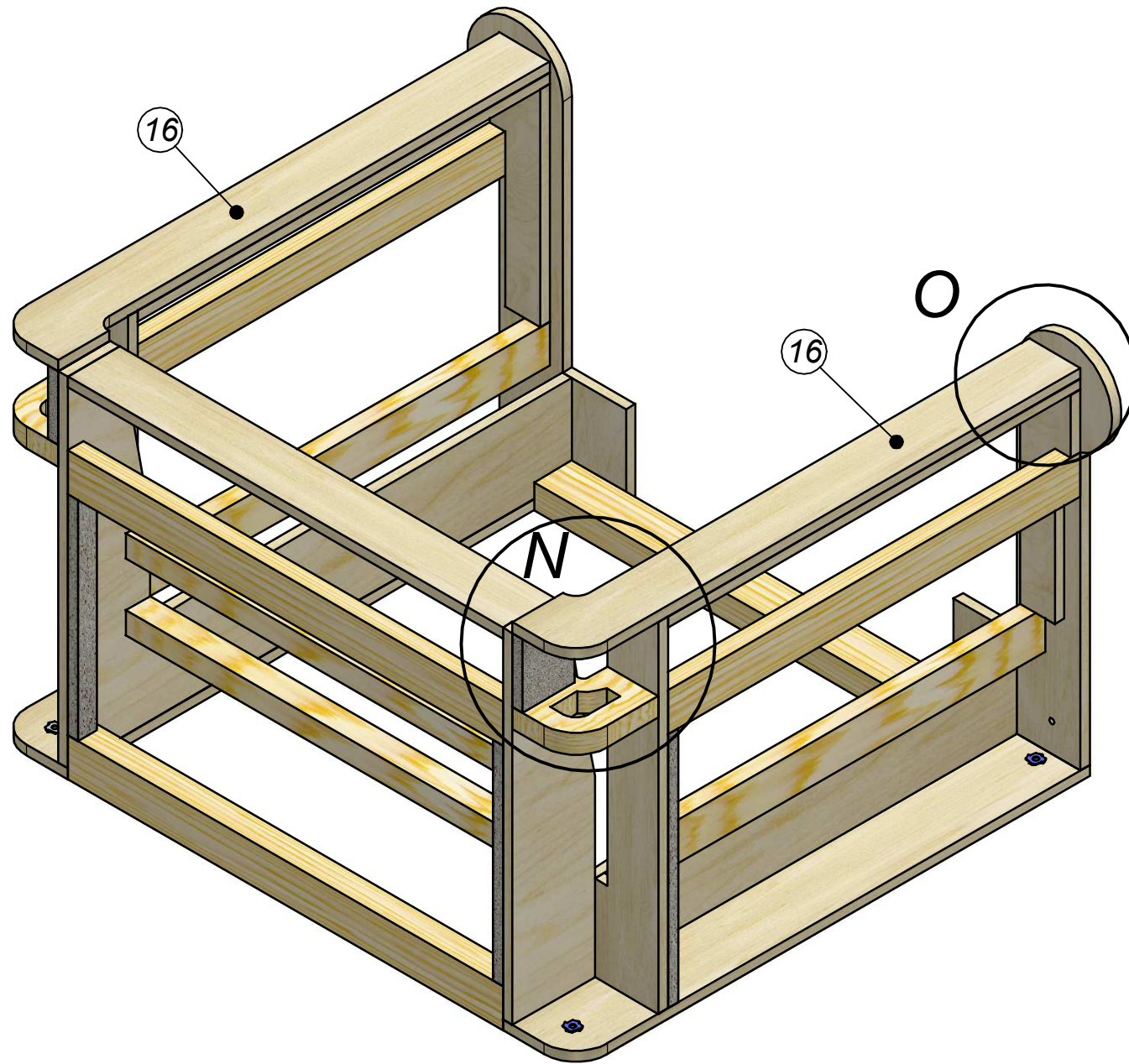

16. 15 mm plywood (Template №6) - 2

Chesterfield chair

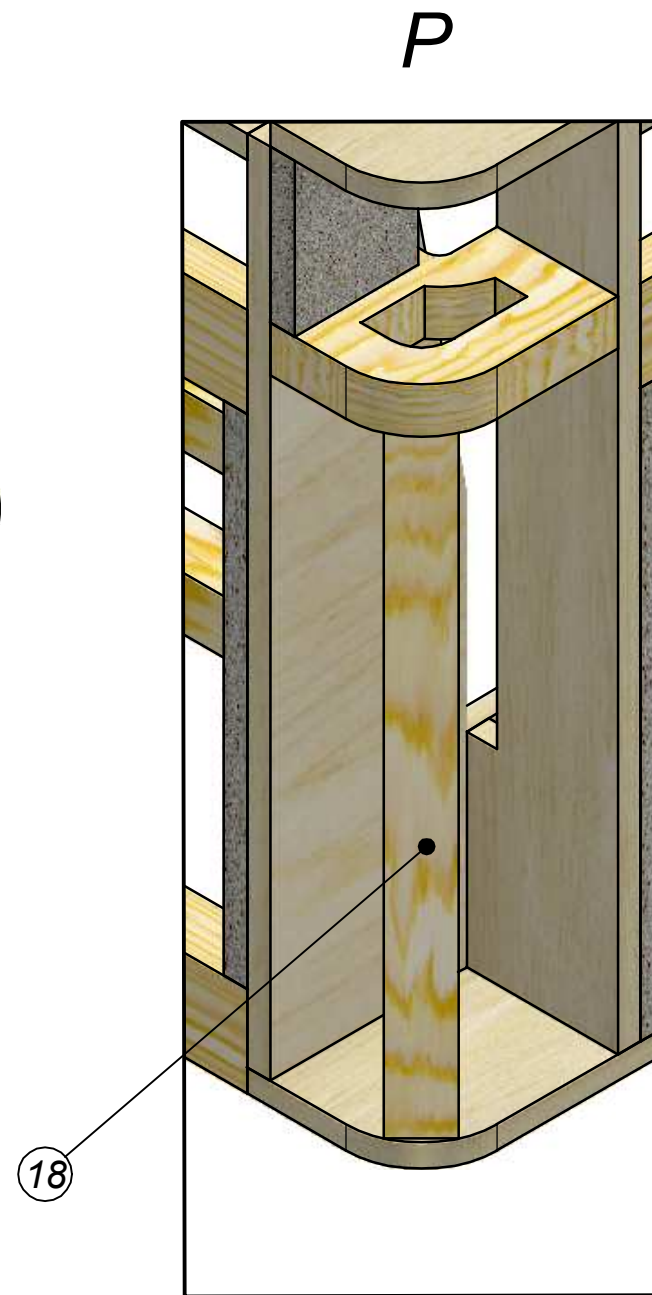
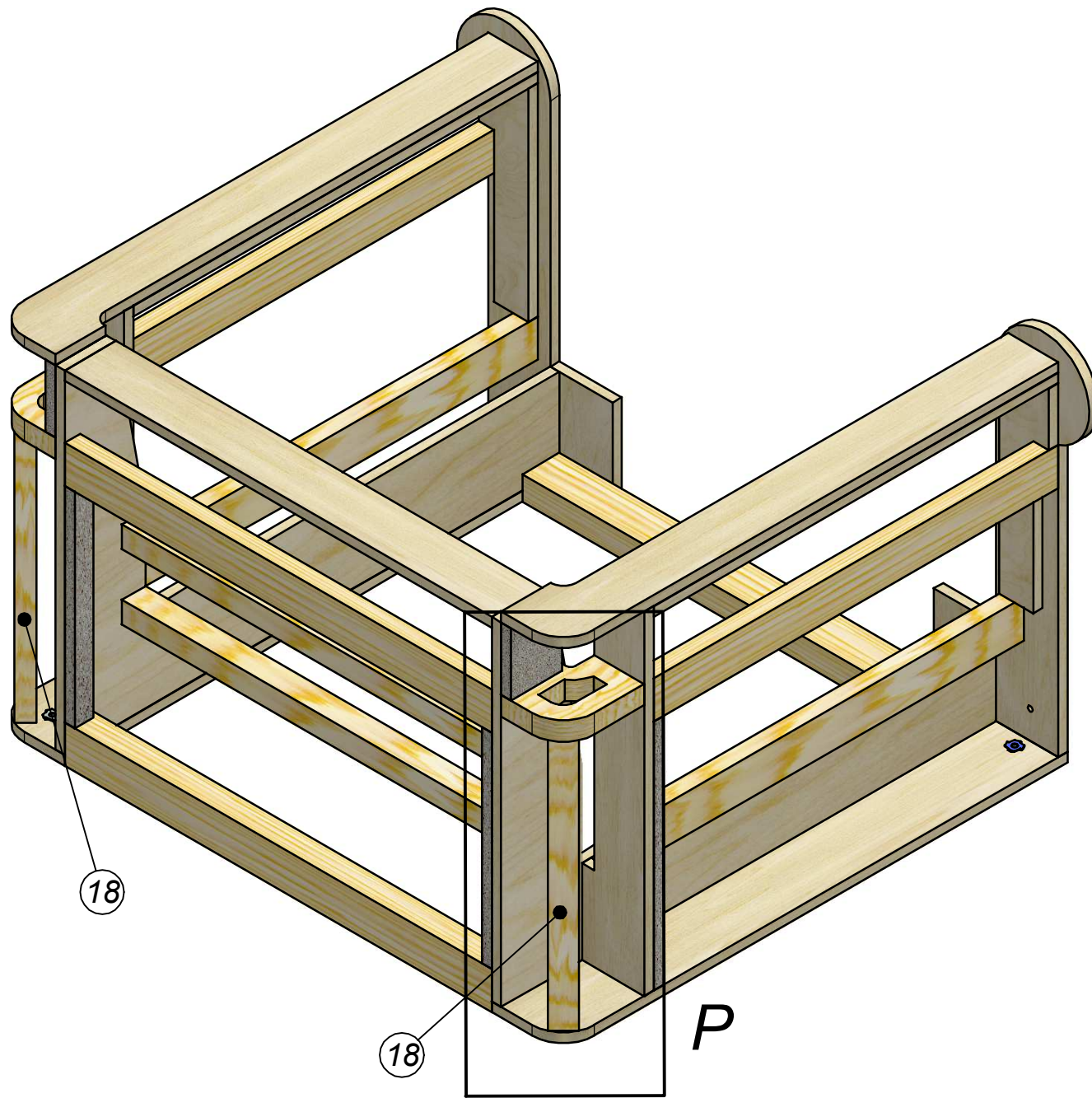

18. Wooden beam 35 x 25 x 404 - 2

Chesterfield chair

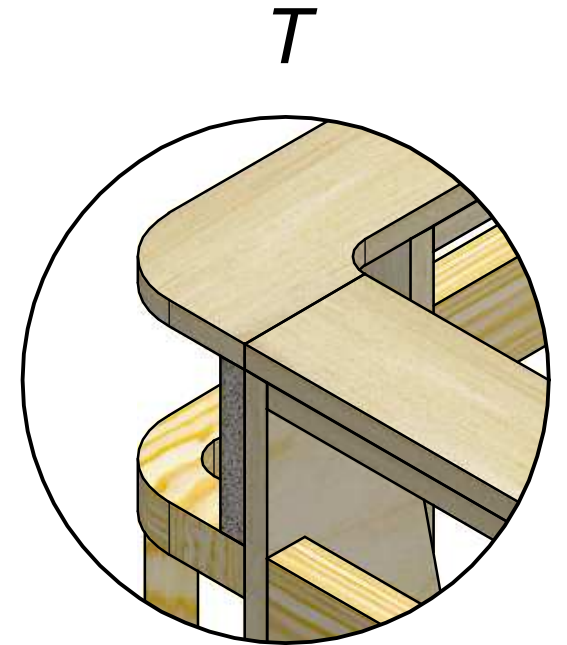
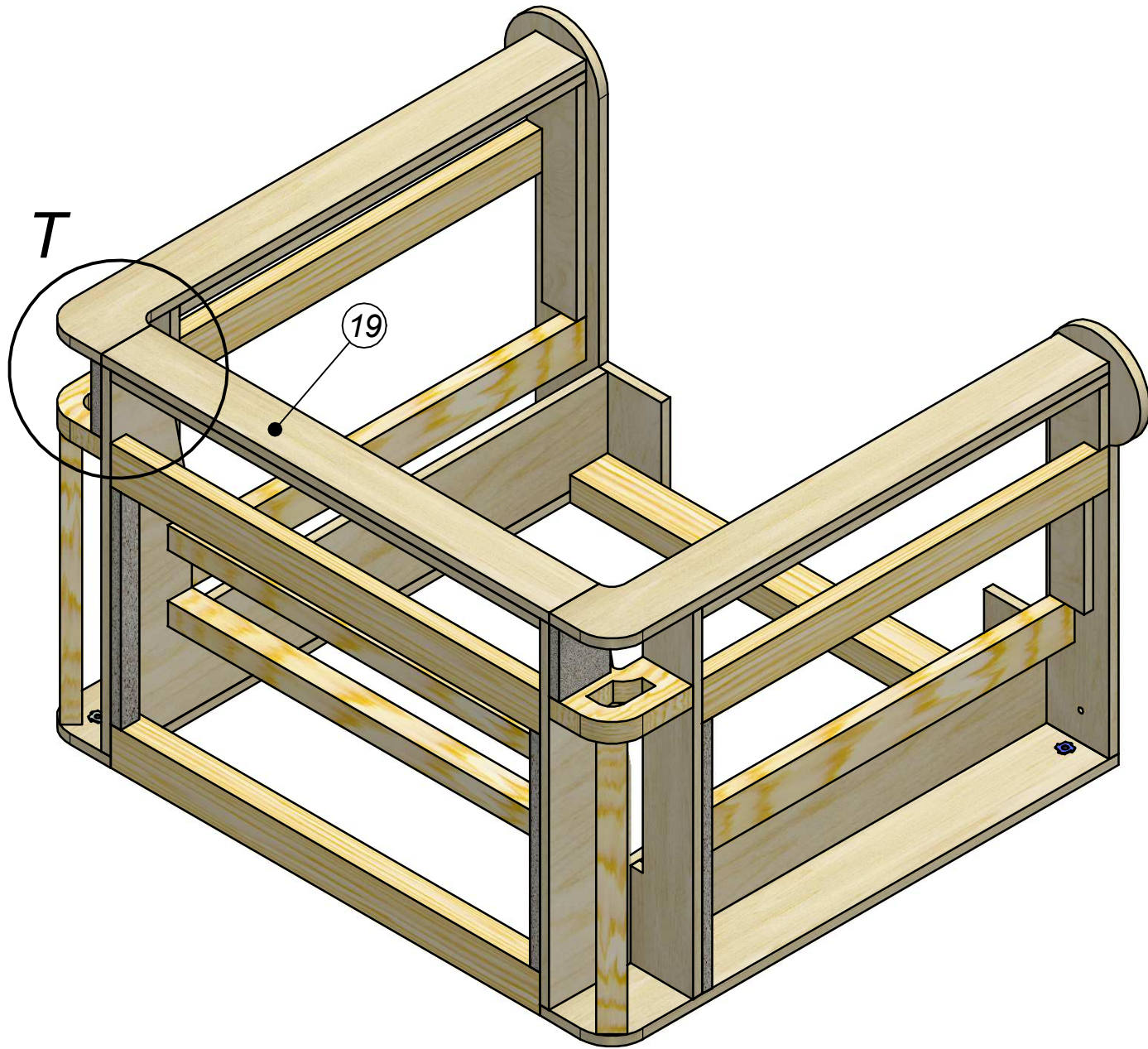

19. 15 mm plywood ( 716 x 80) - 1

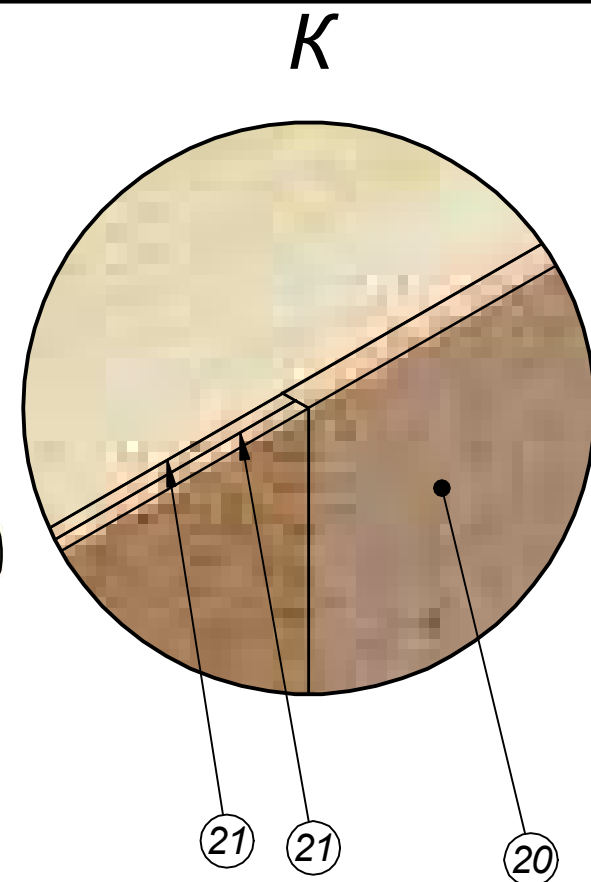
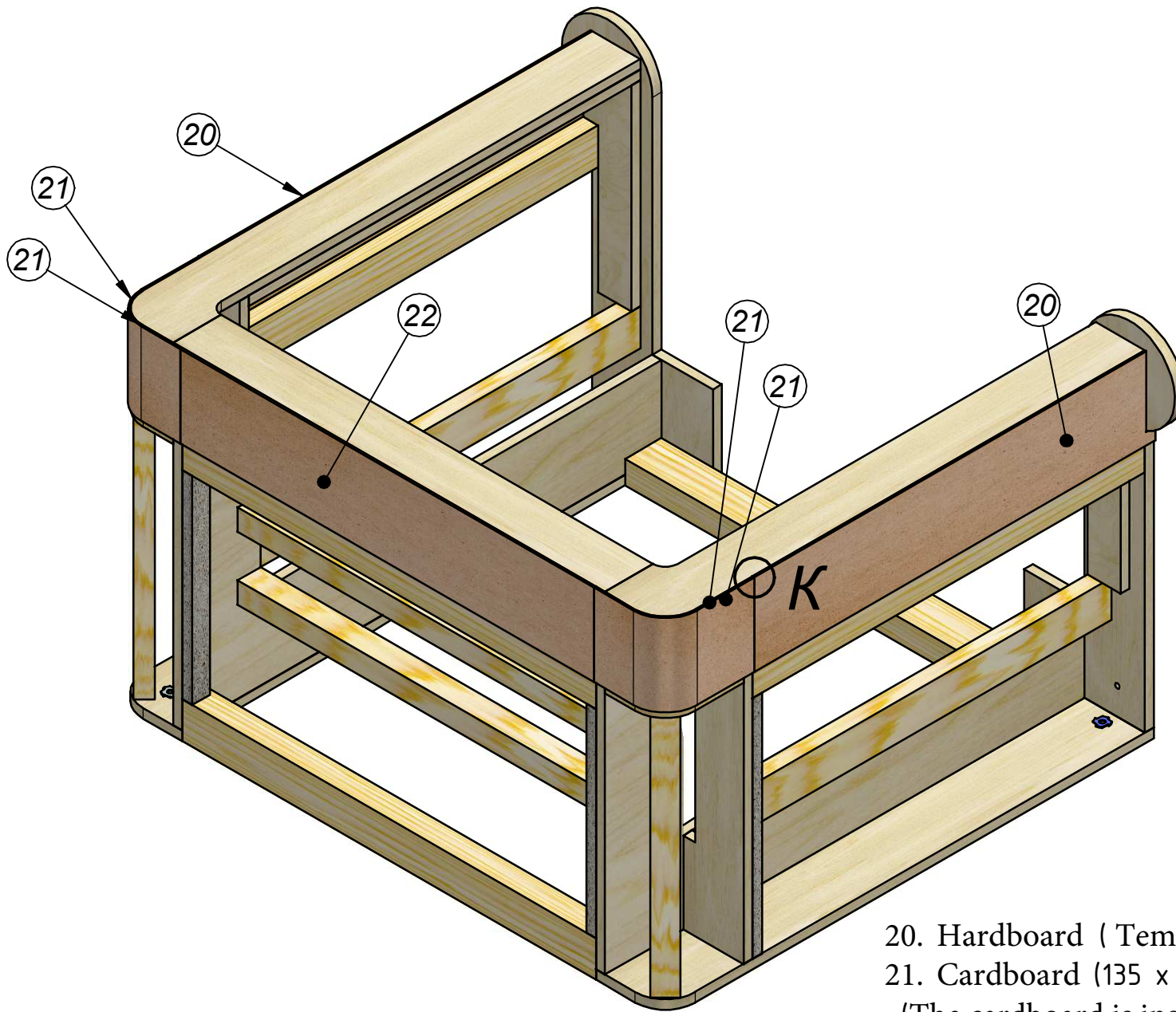

- 20. Hardboard ( Template №8) - 2
- 21. Cardboard (135 x 240) - 4  
(The cardboard is installed in two layers, therefore four pieces are required)
- 22. Hardboard ( 135 x 686) - 1

# Nail the seat frame together

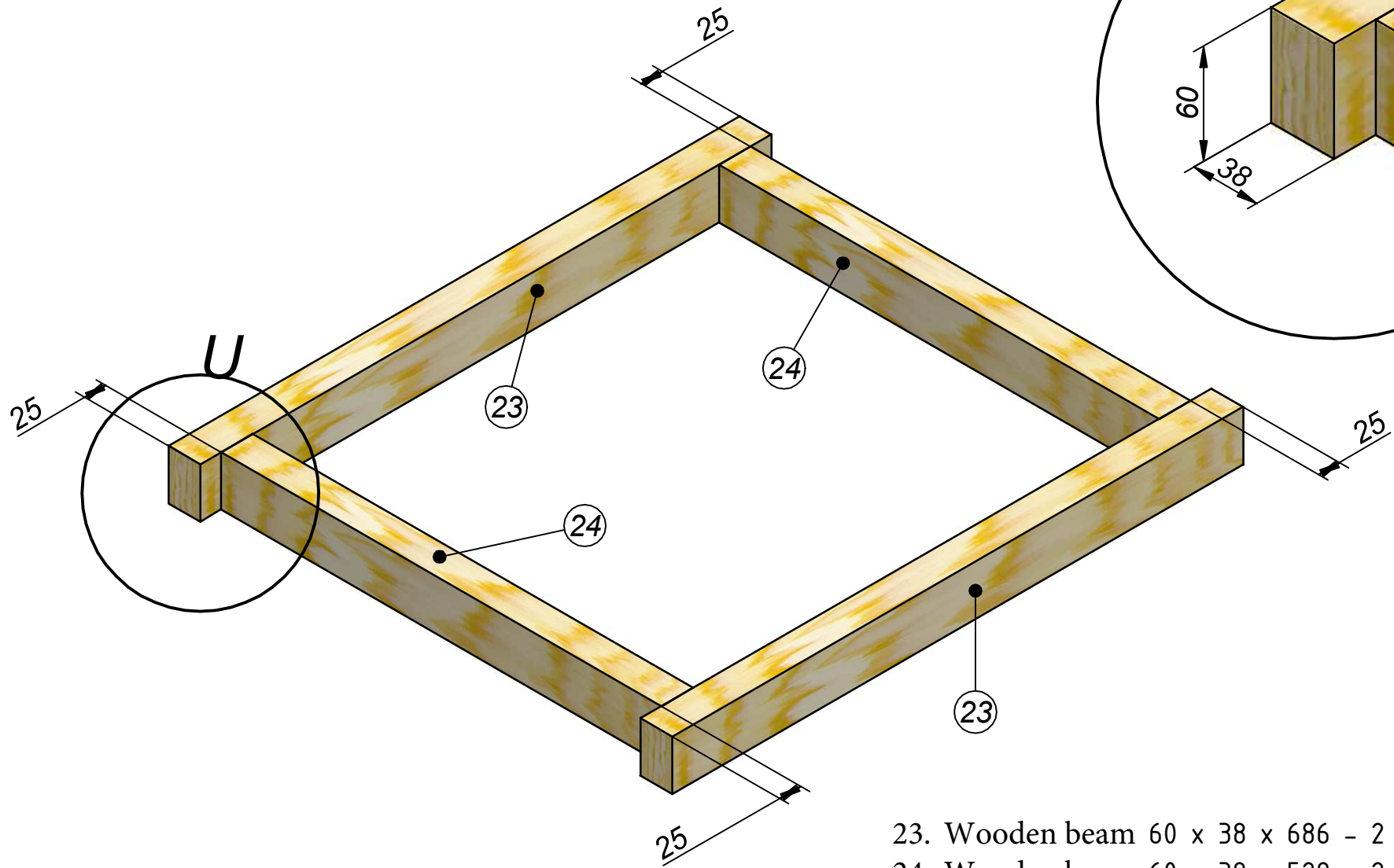

- 23. Wooden beam 60 x 38 x 686 - 2
- 24. Wooden beam 60 x 38 x 529 - 2
- Nail together using 100 mm nails - 8

# Secure the seat frame into the chair frame

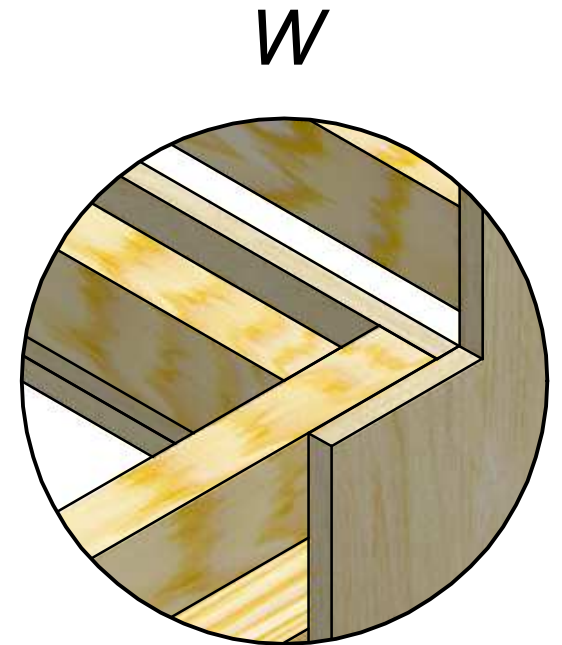
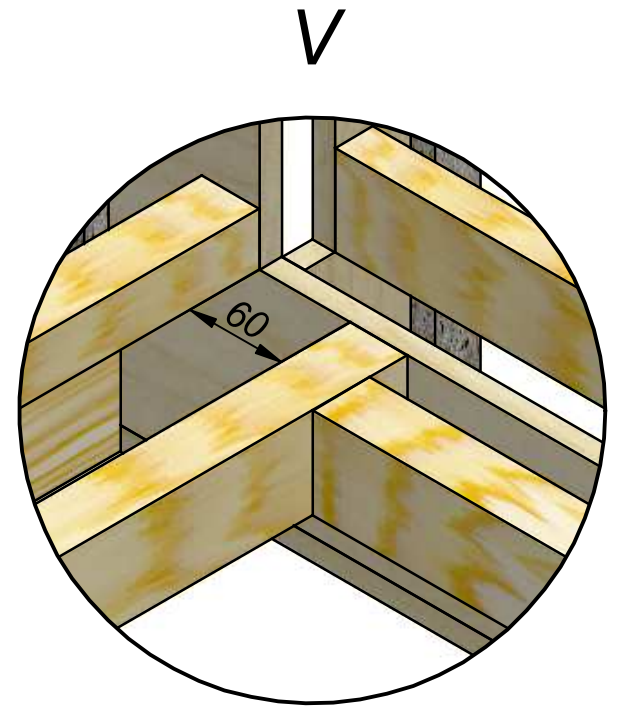
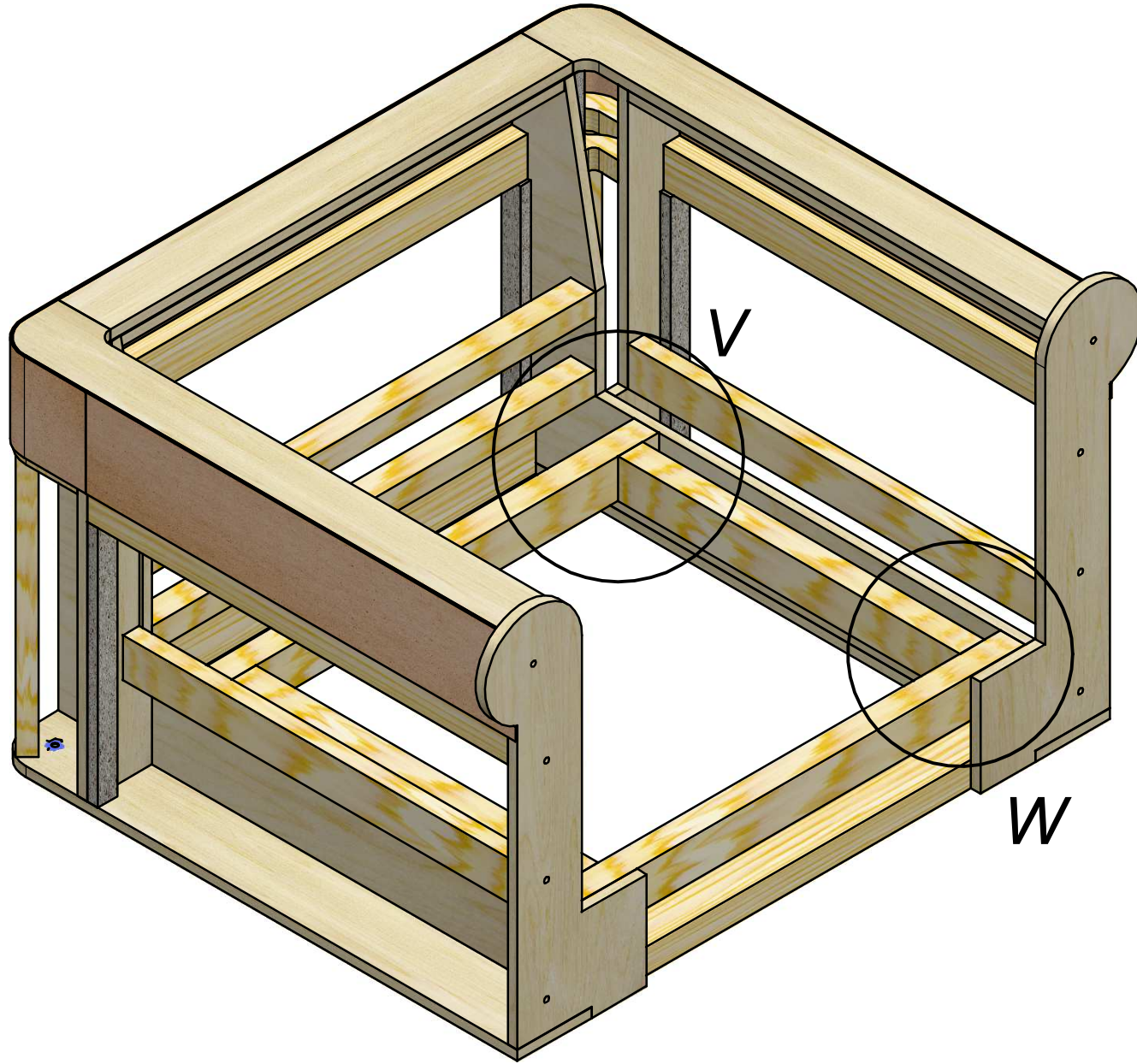

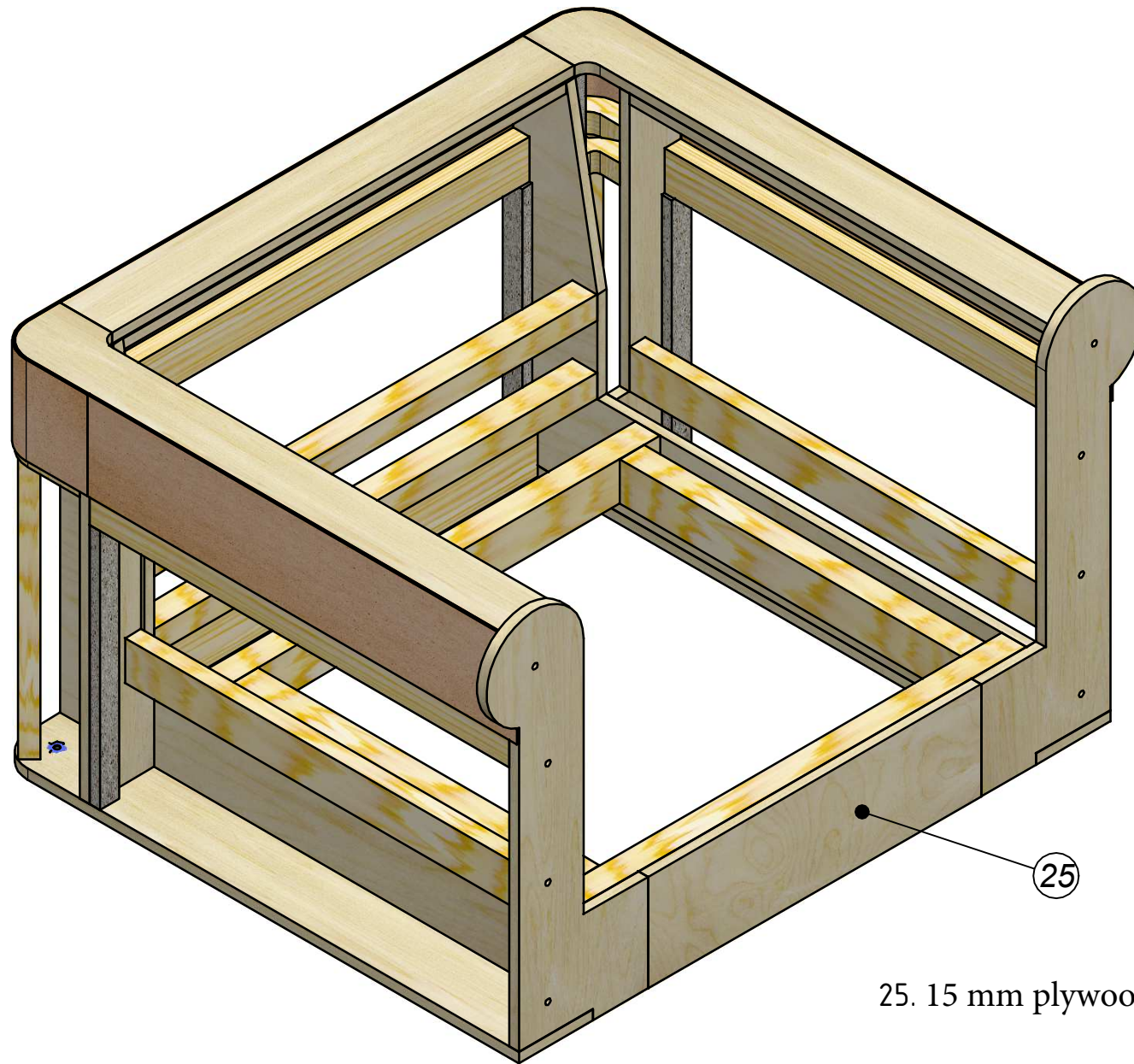

25. 15 mm plywood ( 516 x 150 ) - 1

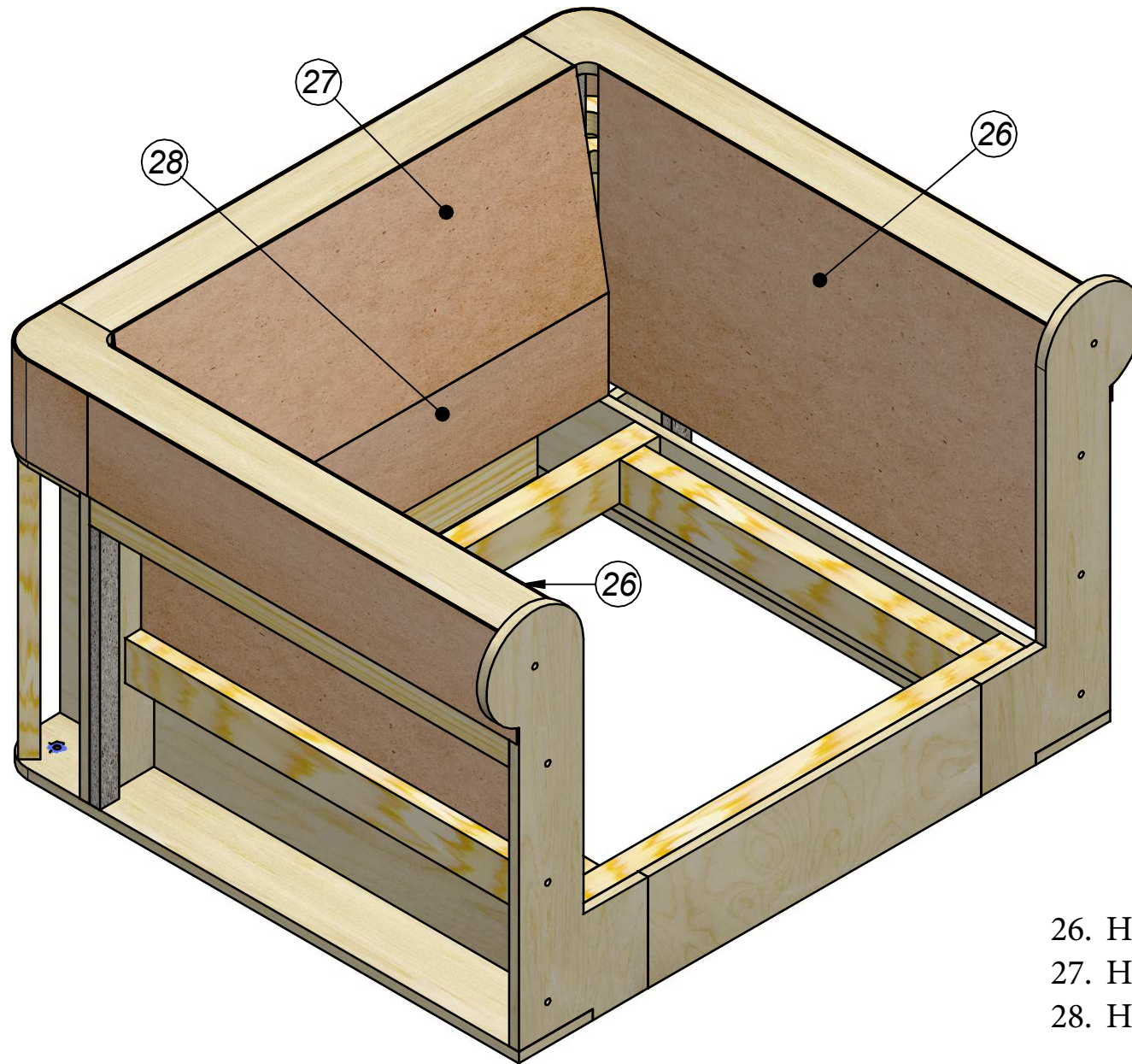

- 26. Hardboard (695 x 415) - 2
- 27. Hardboard (716 x 282) - 1
- 28. Hardboard (716 x 137) - 1

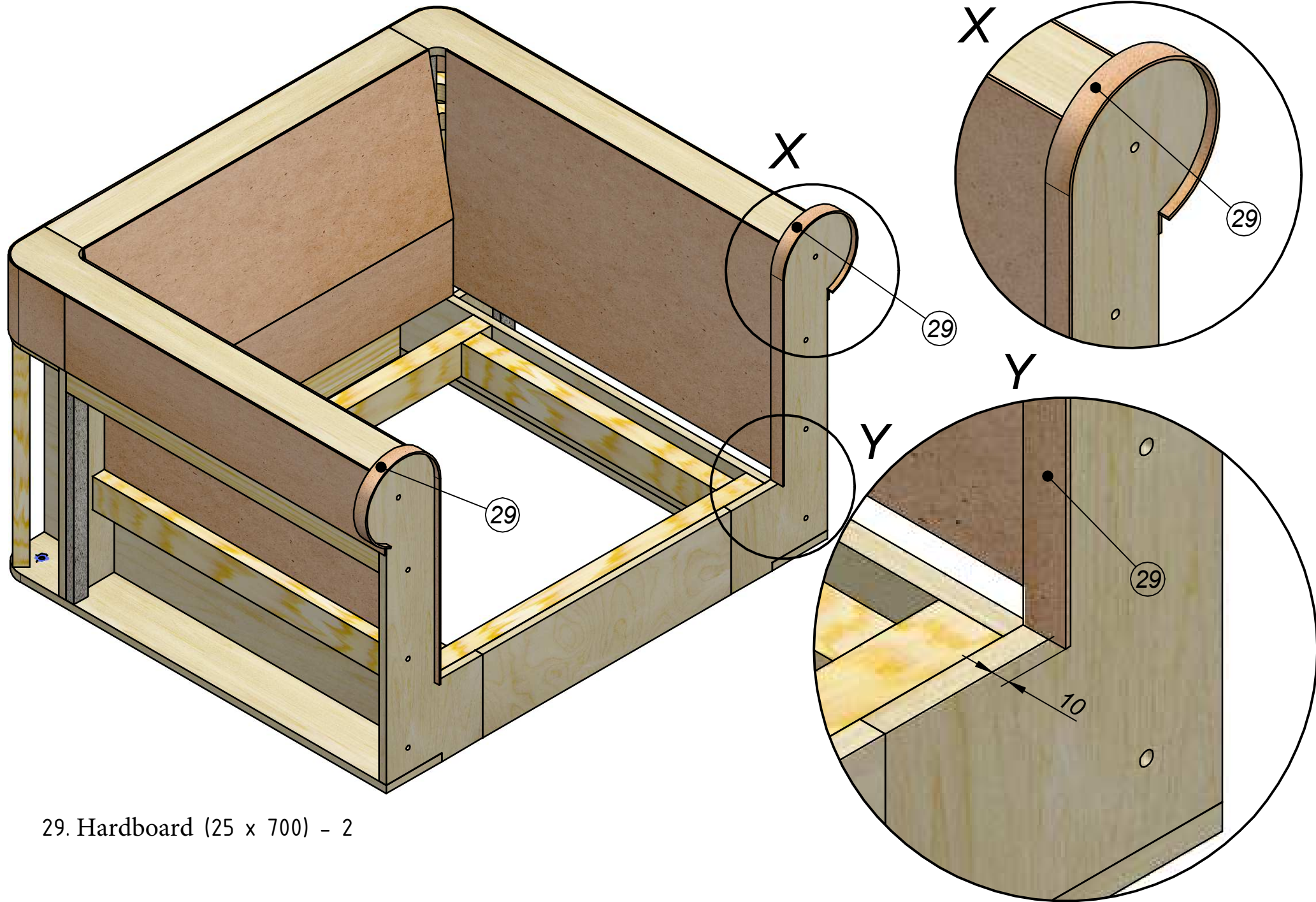

29. Hardboard (25 x 700) - 2

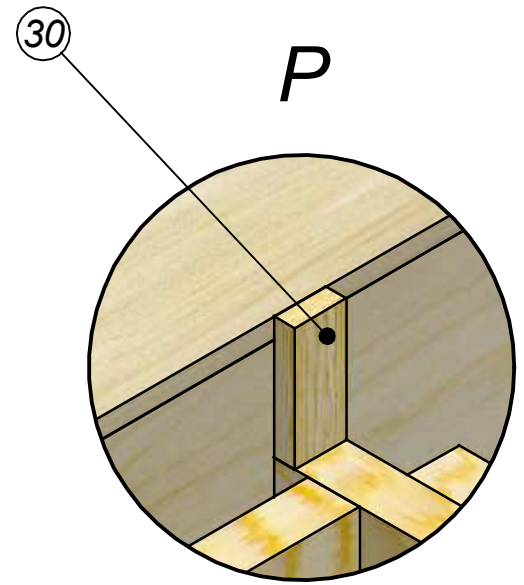
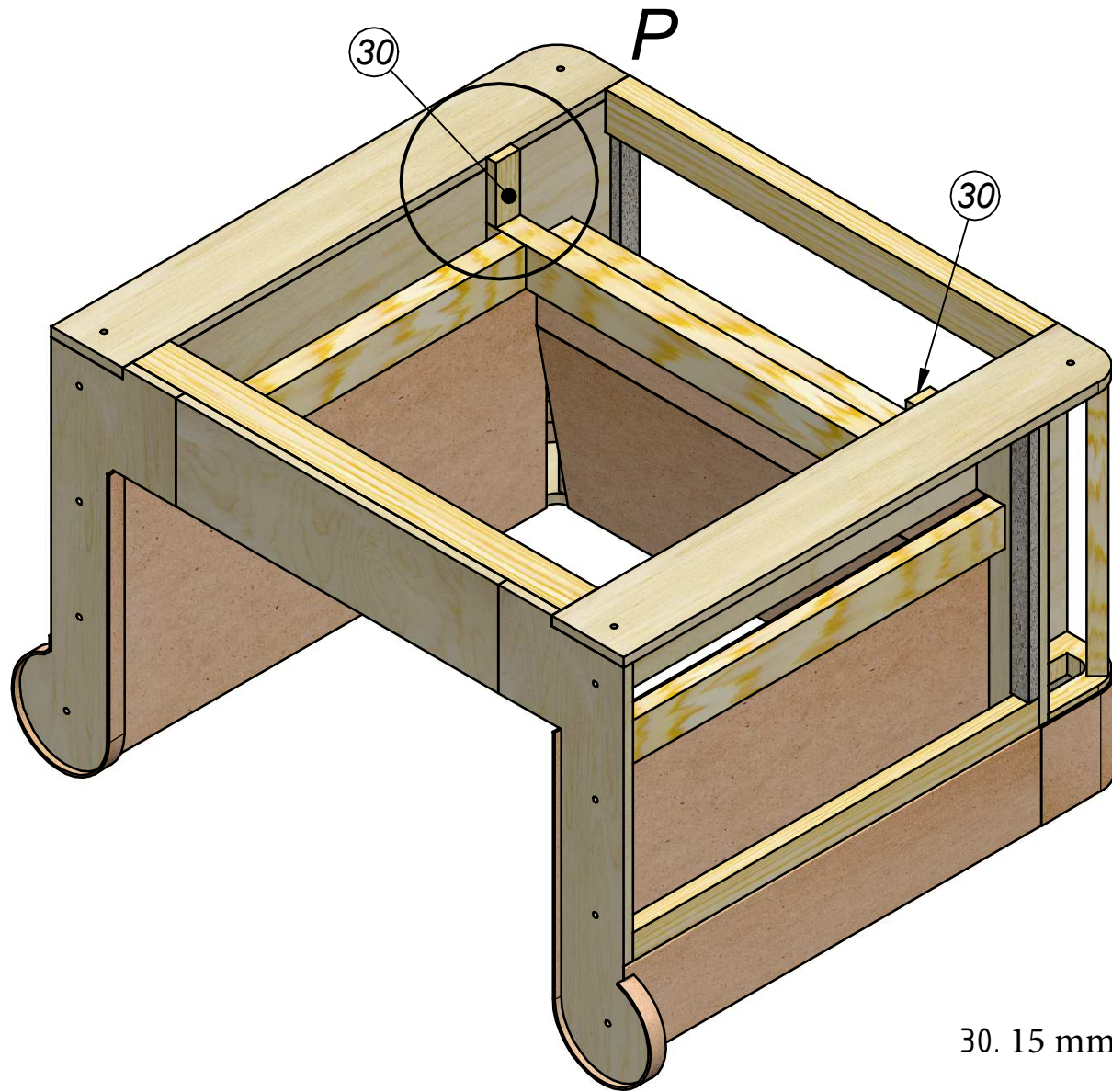

30. 15 mm plywood (90 x 38) - 2

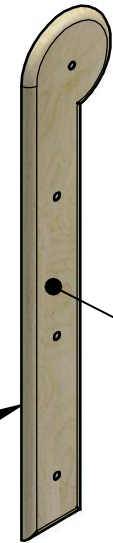
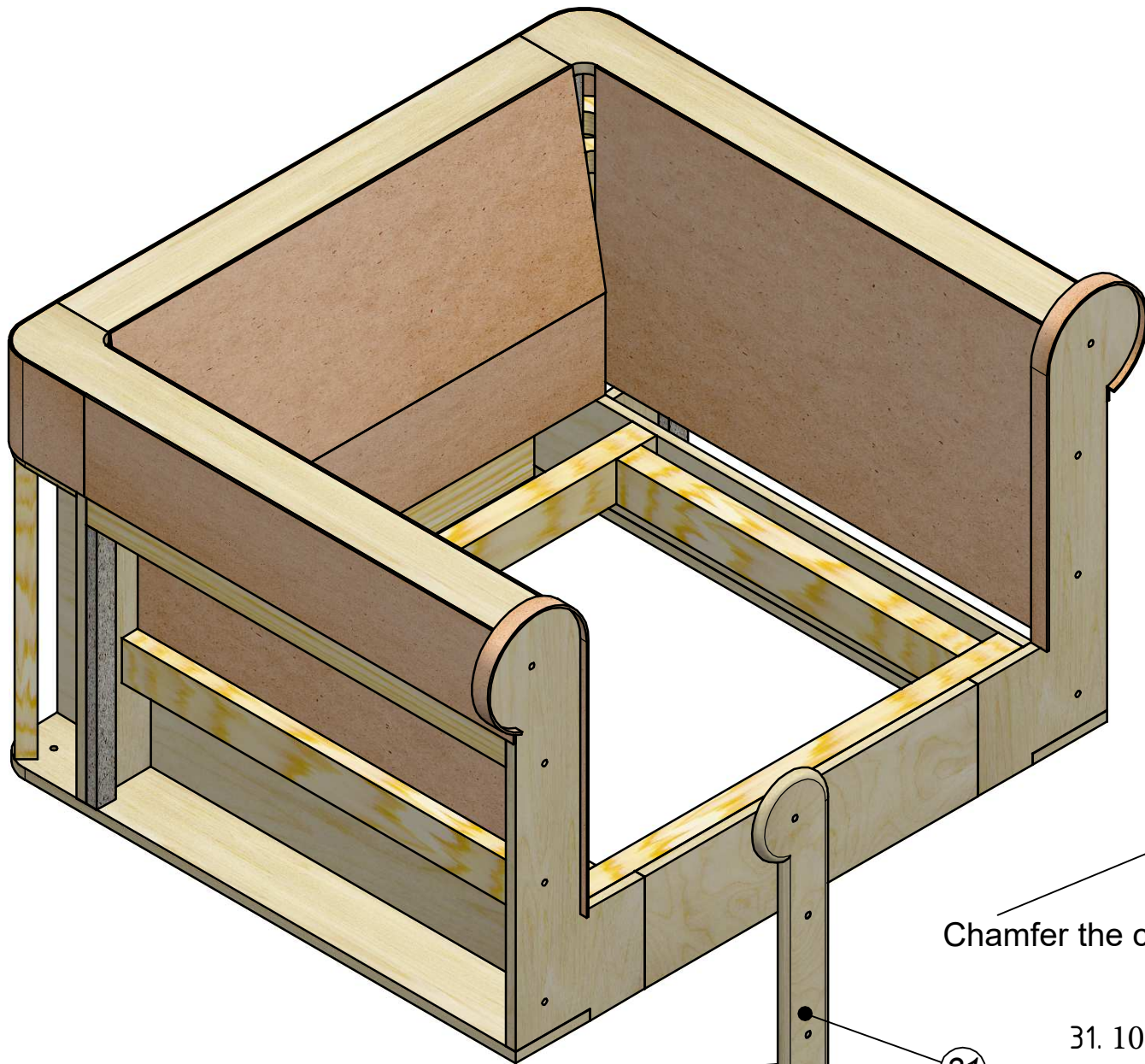

31

Chamfer the corner with a router / milling tool

31. 10 mm plywood (Template №9) - 2

31

Chamfer the corner with a router / milling tool

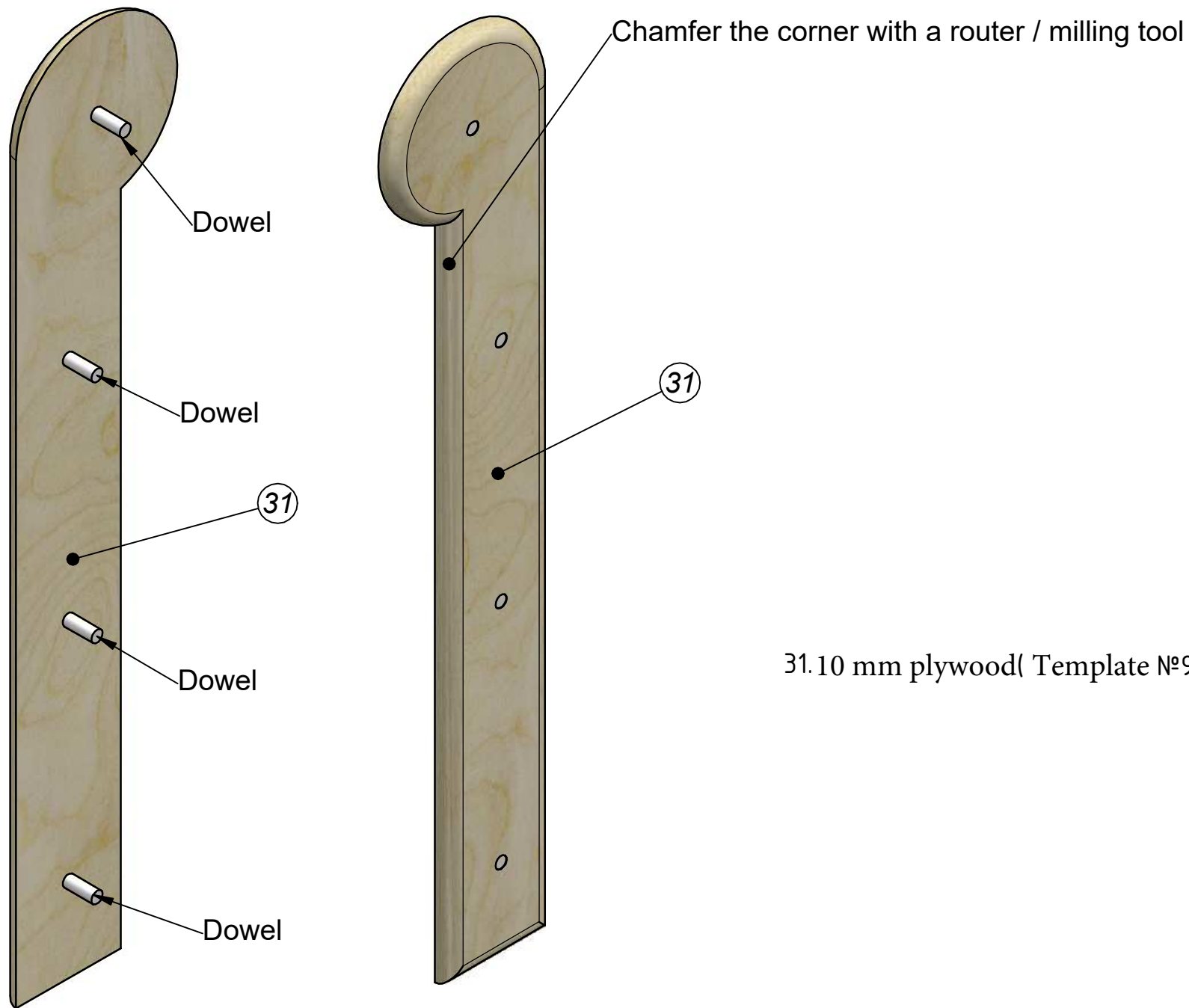

31.10 mm plywood( Template №9)-2

Chesterfield chair

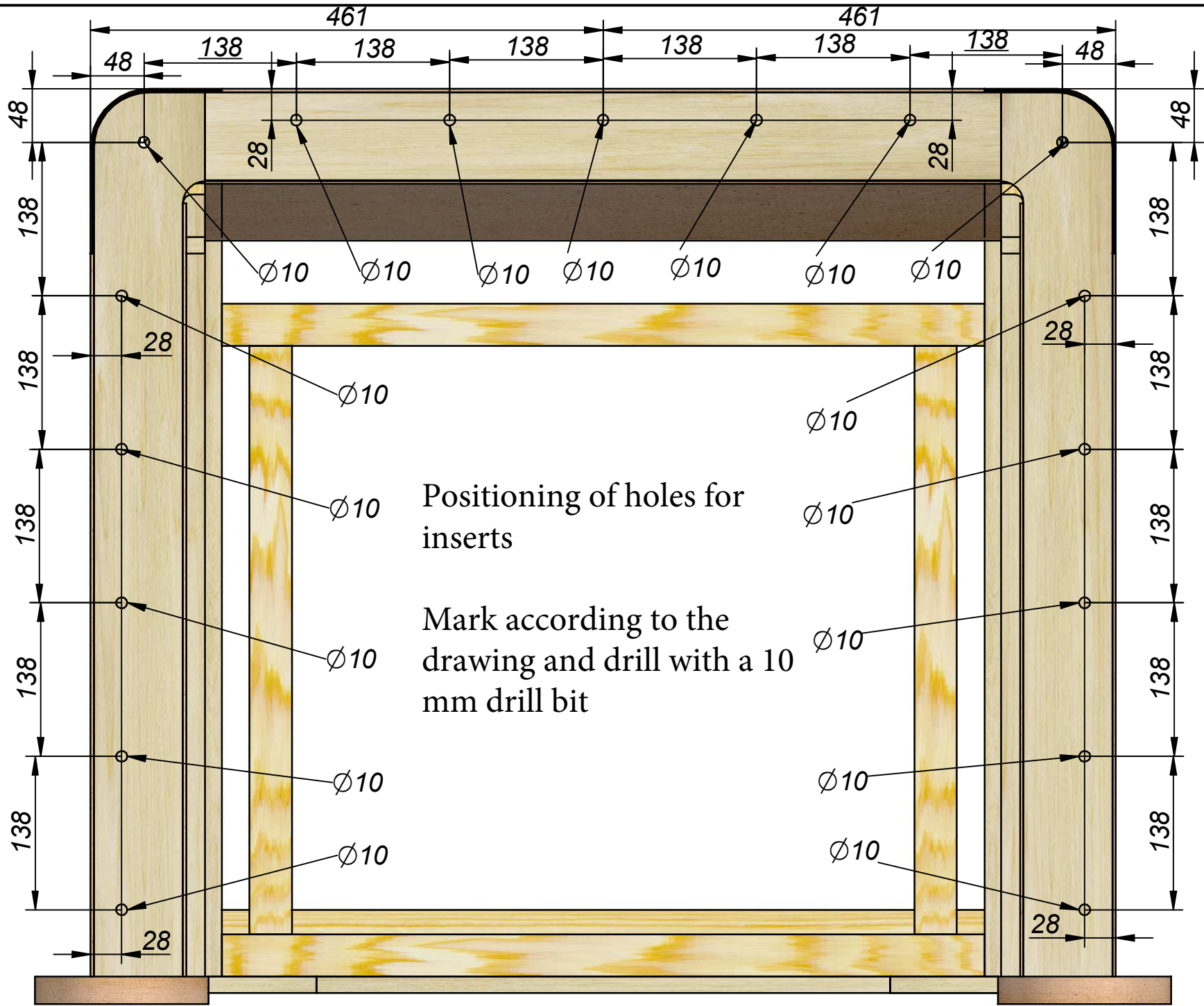

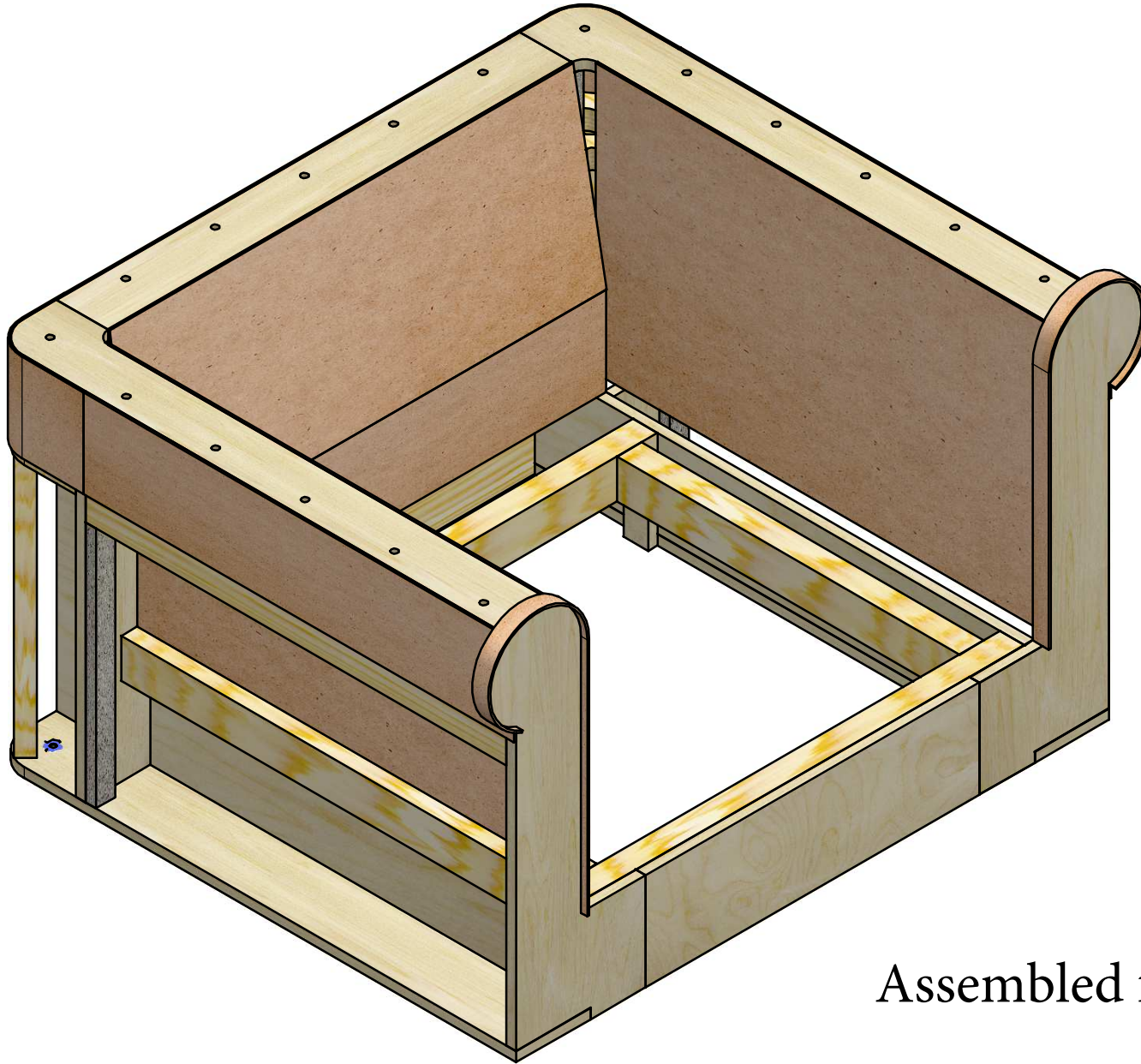

Assembled frame